

MOTORHOME SERIES

3000/4000

OPERATOR'S MANUAL



MOTORHOME SERIES



Operator's Manual

2005 FEBRUARY

OM3349EN

Allison Transmission

VOCATIONAL MODELS

Motorhome Series (MH) Transmissions

3000 and 4000 Product Families

WTEC III Controls and Allison 4th Generation Controls

3000 MH

4000 MH



Allison Transmission, General Motors Corporation
P.O. Box 894 Indianapolis, Indiana 46206-0894
www.allisontransmission.com

NOTES

TABLE OF CONTENTS

INTRODUCTION

KEEPING THAT ALLISON ADVANTAGE	7
A BRIEF DESCRIPTION OF THE ALLISON MOTORHOME SERIES TRANSMISSIONS	12
ELECTRONIC CONTROL SYSTEM	12
TORQUE CONVERTER	13
PLANETARY GEARS AND CLUTCHES	14
COOLER CIRCUIT	14
RETARDER	15

SHIFT SELECTORS

DESCRIPTION OF AVAILABLE TYPES	16
INTRODUCTION	17
LEVER SHIFT SELECTOR	18
PUSHBUTTON SHIFT SELECTOR	20
RANGE SELECTION	21

DRIVING TIPS

CHECK TRANS LIGHT	26
DIAGNOSTIC CODES	27
ACCELERATOR CONTROL	27
DOWNSHIFT AND DIRECTION CHANGE INHIBITOR FEATURE	27
USING THE ENGINE TO SLOW THE VEHICLE	29
USING THE HYDRAULIC RETARDER	29
ADAPTING SHIFTS	32
RANGE PRESELECTION	34
COLD WEATHER STARTS	34
DRIVING ON SNOW OR ICE	35
ROCKING OUT	36
HIGH FLUID TEMPERATURE	36
PARKING BRAKE	37
TOWING OR PUSHING	38
PRIMARY/SECONDARY SHIFT SCHEDULES	38
CRUISE CONTROL OPERATION	38
TURNING OFF THE VEHICLE	39

POWER TAKEOFF OPERATION

ENGINE-DRIVEN POWER TAKEOFF (PTO)	40
---	----

CARE AND MAINTENANCE

PERIODIC INSPECTIONS	41
PREVENT MAJOR PROBLEMS	41
IMPORTANCE OF PROPER FLUID LEVEL	42
FLUID LEVEL CHECK USING PUSHBUTTON OR LEVER SHIFT SELECTOR	43
MANUAL FLUID CHECK PROCEDURE	47
COLD CHECK	49
HOT CHECK	50
RECOMMENDED AUTOMATIC TRANSMISSION FLUID AND VISCOSITY GRADE	50
KEEPING FLUID CLEAN	51
FLUID AND INTERNAL FILTER CHANGE INTERVAL RECOMMENDATIONS	52
TRANSMISSION FLUID CONTAMINATION	56
TRANSMISSION FLUID AND FILTER CHANGE PROCEDURE	57

DIAGNOSTICS

DIAGNOSTIC CODES	60
DIAGNOSTIC CODES	61
DIAGNOSTIC CODE DISPLAY PROCEDURE	63
DIAGNOSTIC CODE LISTINGS AND PROCEDURES (WTEC III CONTROLS)	65
DIAGNOSTIC CODE LISTINGS AND PROCEDURES (ALLISON 4 th GENERATION CONTROLS)	73

ABBREVIATIONS AND DEFINITIONS

ABBREVIATIONS AND DEFINITIONS	84
---	----

CUSTOMER SERVICE

OWNER ASSISTANCE	86
SERVICE LITERATURE	88
ALLISON TRANSMISSION DISTRIBUTORS	90
ALLISON TRANSMISSION REGIONAL OFFICES	92

TRADEMARK USAGE

The following trademarks are the property of the companies indicated:

- Allison DOC™ is a trademark of General Motors Corporation.
- DEXRON® is a registered trademark of the General Motors Corporation.
- TranSynd™ is a trademark of Castrol Ltd.

WARNINGS, CAUTIONS, NOTES

IT IS YOUR RESPONSIBILITY to be completely familiar with the warnings and cautions described in this manual. It is, however, important to understand that these warnings and cautions are not exhaustive. Allison Transmission could not possibly know, evaluate, and advise the service trade of all conceivable ways in which service might be done or of the possible hazardous consequences of each way. The vehicle manufacturer is responsible for providing information related to the operation of vehicle systems (including appropriate warnings, cautions, and notes). Consequently, Allison Transmission has not undertaken any such broad evaluation. Accordingly, **ANYONE WHO USES A SERVICE PROCEDURE OR TOOL WHICH IS NOT RECOMMENDED BY ALLISON TRANSMISSION OR THE VEHICLE MANUFACTURER MUST** first be thoroughly satisfied that neither personal safety nor equipment safety will be jeopardized by the service methods selected.

Proper service and repair is important to the safe, reliable operation of the equipment. The service procedures recommended by Allison Transmission (or the vehicle manufacturer) and described in this manual are effective methods for performing service operations. Some of these service operations require the use of tools specially designed for the purpose. The special tools should be used when and as recommended.

Three types of headings are used in this manual to attract your attention. These warnings and cautions advise of specific methods or actions that can result in personal injury, damage to the equipment, or cause the equipment to become unsafe.



WARNING: A warning is used when an operating procedure, practice, etc., if not correctly followed, could result in personal injury or loss of life.



CAUTION: A caution is used when an operating procedure, practice, etc., if not strictly observed, could result in damage to or destruction of equipment.



NOTE: A note is used when an operating procedure, practice, etc., is essential to highlight.

MOTORHOME SERIES

INTRODUCTION

KEEPING THAT ALLISON ADVANTAGE



V01724

Allison **Motorhome Series (MH) transmissions** provide many advantages for the driver who must “stop and go” or change speeds frequently. Driving is easier, safer, and more efficient.

The Motorhome Series transmissions are rugged and designed to provide long, trouble-free service. This manual will help you gain maximum benefits from your **ALLISON**-equipped vehicle.

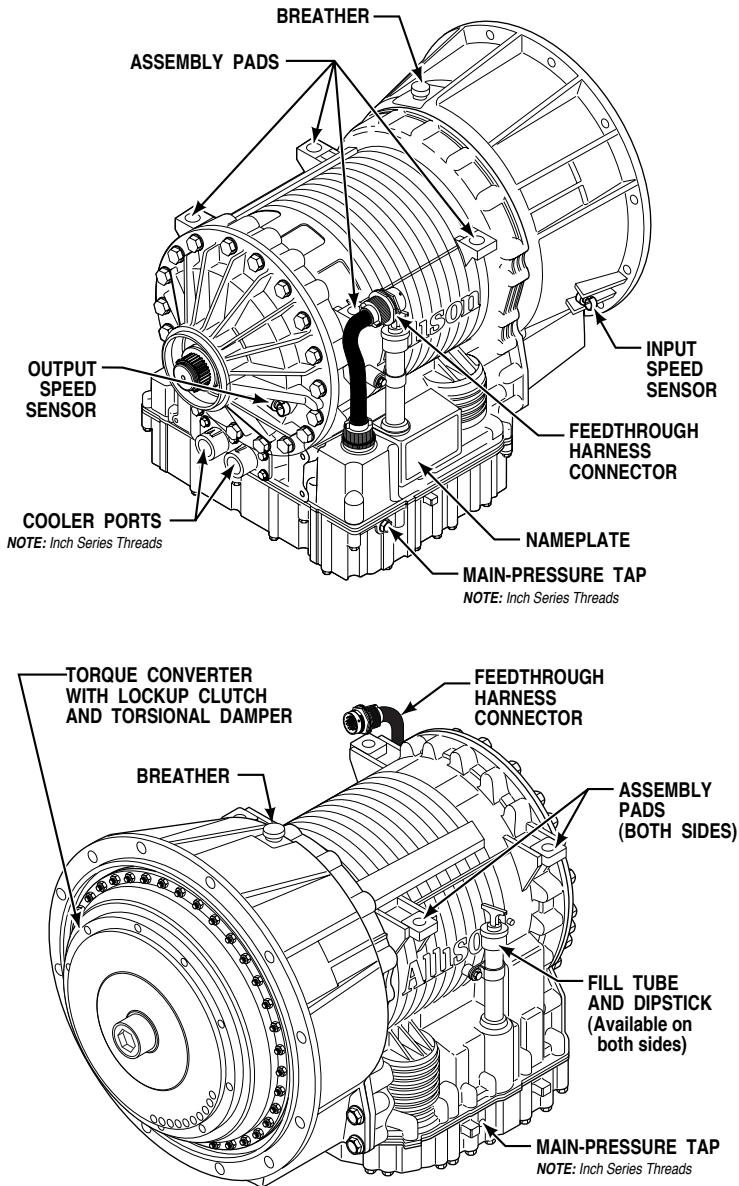

V06341.02.00

Figure 1. Typical 3000 MH Series Transmission (WTEC III Controls)

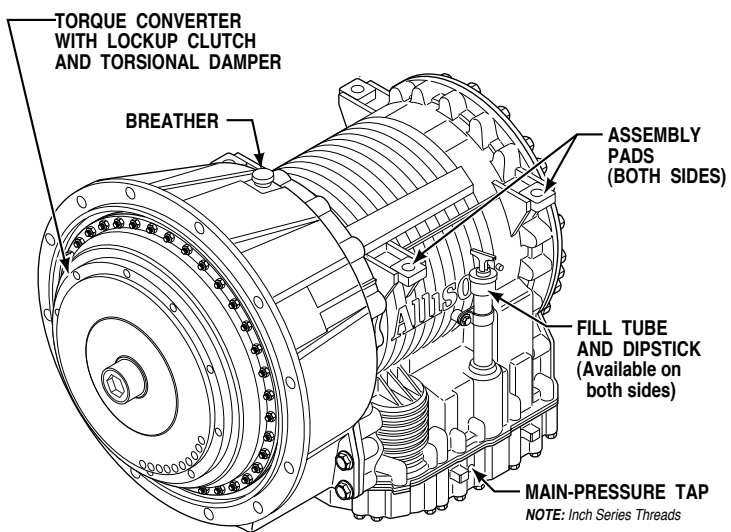
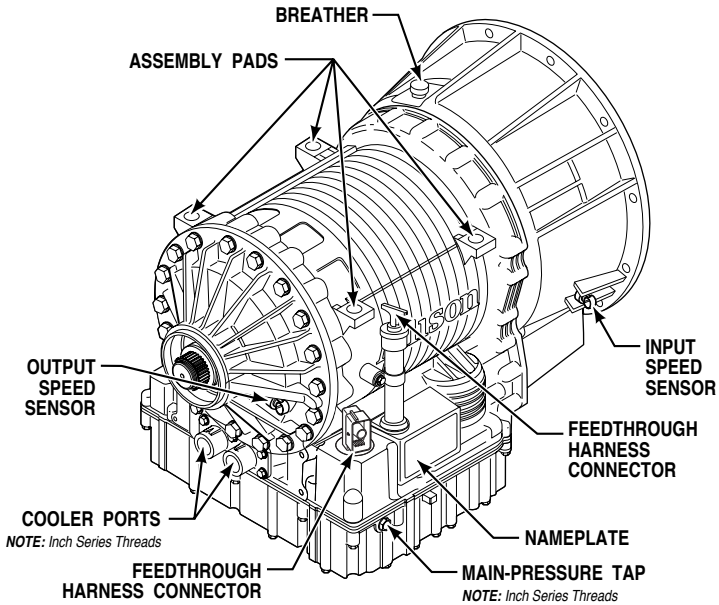

V06341.03.00

Figure 2. Typical 3000 MH Series Transmission (Allison 4th Generation Controls)

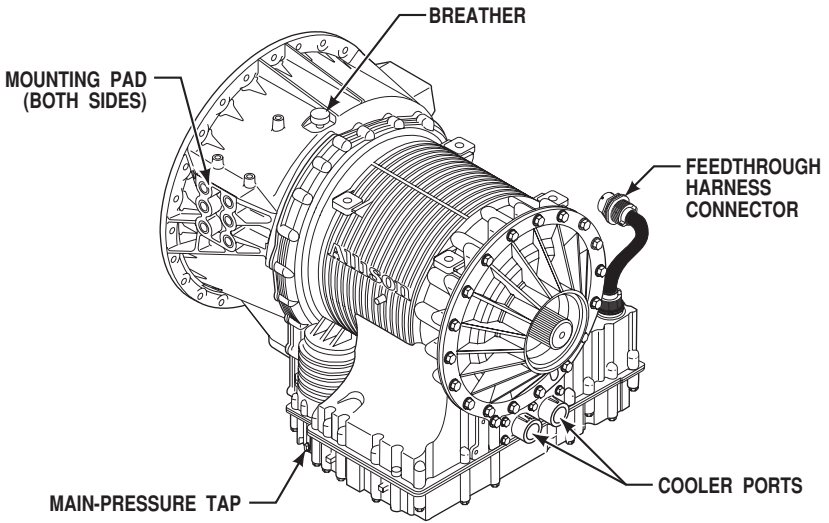
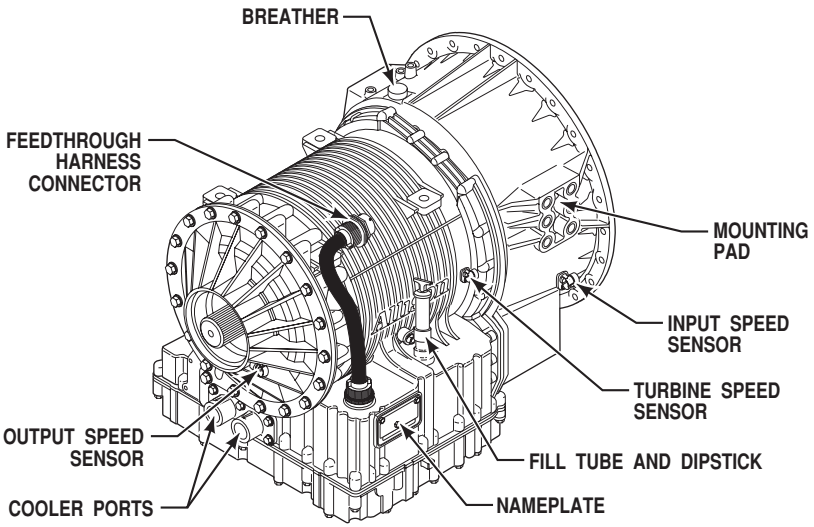

V06342

Figure 3. Typical 4000 MH Series Transmission (WTEC III Controls)

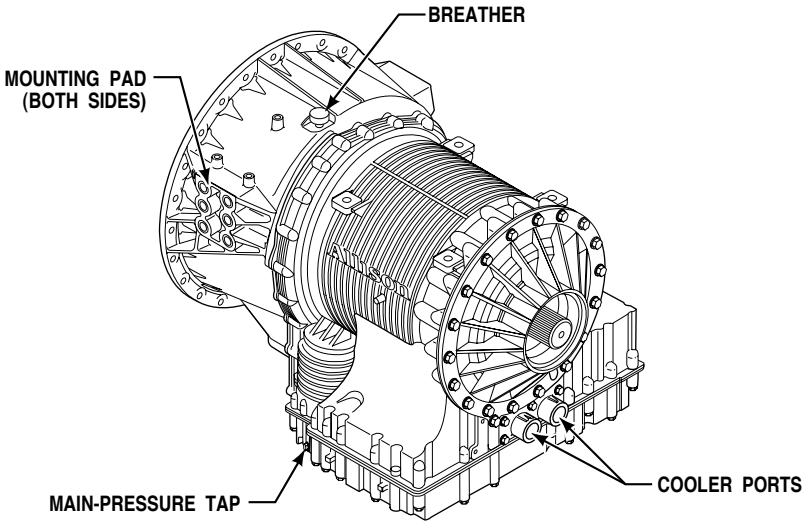
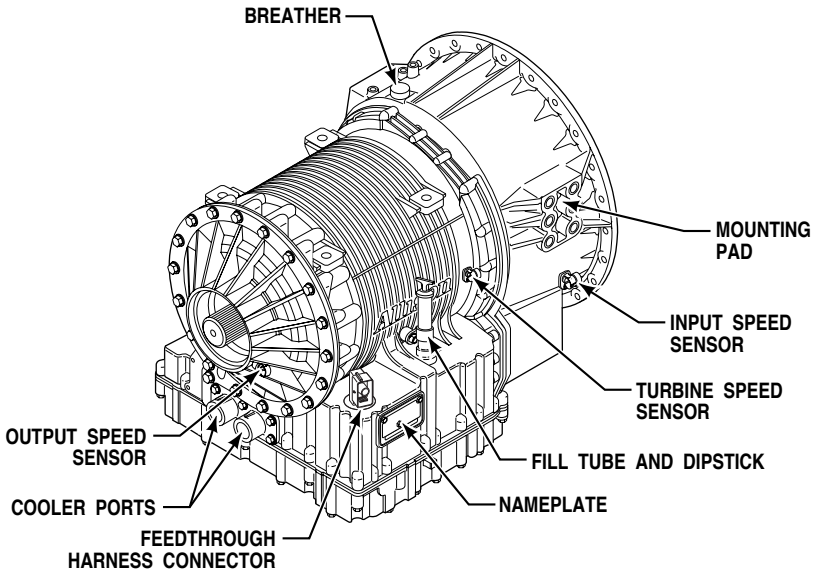

V06342.01.00

Figure 4. Typical 4000 MH Series Transmission
(Allison 4th Generation Controls)

A BRIEF DESCRIPTION OF THE ALLISON MOTORHOME SERIES TRANSMISSIONS

Included in the Allison On-Highway Transmission family are the Motorhome Series transmissions. The transmissions described in this manual include:

- WTEC III Controls or Allison 4th Generation Controls
- A torque converter with lockup and torsion damper
- Three planetary gear sets

Motorhome Series transmissions may contain an integral retarder or a provision to mount a Power Takeoff (PTO).

ELECTRONIC CONTROL SYSTEM

All Motorhome Series transmissions come standard with WTEC III Controls or Allison 4th Generation Controls. These systems consist of five major components connected by OEM-furnished wiring harnesses. The five major components are:

- Transmission Control Module (TCM) or Electronic Control Unit (ECU)
- Three speed sensors
- Remote shift selector
- Control module (which contains solenoid valves, a pressure switch, and an optional oil level sensor)
- Engine Electronic Control Module (ECM) or Engine Throttle Position Sensor (TPS), if installed

The TCM/ECU receives information from the following:

- Throttle position sensor, if installed
- Speed sensors
- Pressure switch
- Shift selector

The TCM/ECU processes information and then sends signals to actuate specific solenoids located in the control valve module. These solenoids control both oncoming and offgoing clutch pressures to provide closed-loop shift control by matching input rpm during a shift to a desired profile programmed into the TCM/ECU.

A feature of both Allison 4th Generation Controls and WTEC III controls is “autodetect.” Autodetect is active within the first several engine starts, depending upon the component or sensor being detected. These engine start cycles begin when the transmission is installed during vehicle manufacture. Autodetect searches for the presence of the following transmission components or data inputs:

Transmission Components

Retarder	Present, Not Present
Oil Level Sensor (OLS)	Present, Not Present
Throttle	Analog, J1587, J1939
Engine Coolant Temperature	Analog, J1939, J1587

Seek help from the nearest Allison Transmission service outlet when any of the above components are present, but are not responding properly.

Another feature of the Motorhome Series transmission is its ability to adapt or “learn” as it operates. Each shift is measured electronically, stored, and used by the TCM/ECU to adapt or “learn” the optimum control for future shifts.



NOTE: Allison 4th Generation Controls and WTEC III Controls are designed and manufactured to comply with all FCC and other guidelines regarding radio frequency interference/electromagnetic interference (RFI/EMI) for transportation electronics. Manufacturers, assemblers, and installers of radio-telephone or other two-way communication radios have the sole responsibility to correctly install and integrate those devices into Allison Motorhome Series transmission-equipped vehicles to customer satisfaction.

The TCM/ECU is programmed to provide the most suitable operating characteristics for a specific application. This manual does not attempt to describe all of the possible combinations. The information contained herein describes only the operating characteristics most frequently requested by the vehicle manufacturer.

TORQUE CONVERTER

The torque converter consists of the following four elements:

- Pump—input element driven directly by the engine
- Turbine—output element hydraulically driven by the pump
- Stator—reaction (torque multiplying) element
- Lockup Clutch—mechanically couples the pump and turbine when engaged; controlled by TCM/ECU

When the pump turns faster than the turbine, the torque converter is multiplying torque. When the turbine approaches the speed of the pump, the stator starts to rotate with the pump and turbine. When this occurs, torque multiplication stops and the torque converter functions as a fluid coupling.

The lockup clutch is located inside the torque converter and consists of the following elements:

- Piston and backplate—driven by the engine
- Clutch plate/damper (located between the piston and the backplate)—splined to the converter turbine

The lockup clutch/torsional damper is engaged and released in response to electronic signals from the TCM/ECU. Lockup clutch engagement provides a direct drive from the engine to the transmission gearing. This eliminates converter slippage and maximizes fuel economy and vehicle speed. The lockup clutch releases at lower speeds or when the TCM/ECU detects conditions requiring it to be released.

The torsional damper absorbs engine torsional vibration to prevent transmitting vibrations through the powertrain.

PLANETARY GEARS AND CLUTCHES

A series of three helical planetary gear sets and shafts provides the mechanical gear ratios and direction of travel for the vehicle. The planetary gear sets are controlled by five multiplate clutches that work in pairs to produce up to six forward speeds and one reverse speed. The clutches are applied and released hydraulically in response to electronic signals from the TCM/ECU to the appropriate solenoids.

COOLER CIRCUIT

The transmission fluid is cooled by an integral (transmission-mounted) or remote-mounted oil cooler. Connections to the cooling circuit are located at the front or rear of the transmission to facilitate installation of remote cooler lines. On retarder models, only the rear cooler ports may be used. The integral cooler is mounted on the lower rear portion of the transmission, replacing the remote cooler manifold. Integral cooler oil ports are internal requiring coolant to be routed to and from the cooler.

A new feature has been added on all retarder-equipped transmissions. The retarder housing now allows addition of either a remote or integral cooler for transmission sump fluid in addition to retarder out fluid. A by-pass cover is placed over the sump cooling ports when the provision is not used. The sump cooler ports are located on the lower right rear face of the retarder housing (refer to Figure 1 through Figure 4).

RETARDER

The self-contained retarder is at the output of the transmission and consists of a vaned rotor which rotates in a vaned cavity. The rotor is splined to and driven by the output shaft. An external accumulator holds transmission fluid until the retarder is activated. When the retarder is activated, the fluid in the accumulator is pressurized by the vehicle air system and directed into the retarder cavity. The interaction of the fluid with the rotating and stationary vanes causes the retarder rotor and output shaft to reduce speed, slowing the vehicle or limiting speed on a downhill grade. Refer to USING THE HYDRAULIC RETARDER for additional information.

When the retarder is deactivated, the retarder cavity is evacuated and the accumulator is recharged with fluid.

MOTORHOME SERIES

SHIFT SELECTORS

DESCRIPTION OF AVAILABLE TYPES

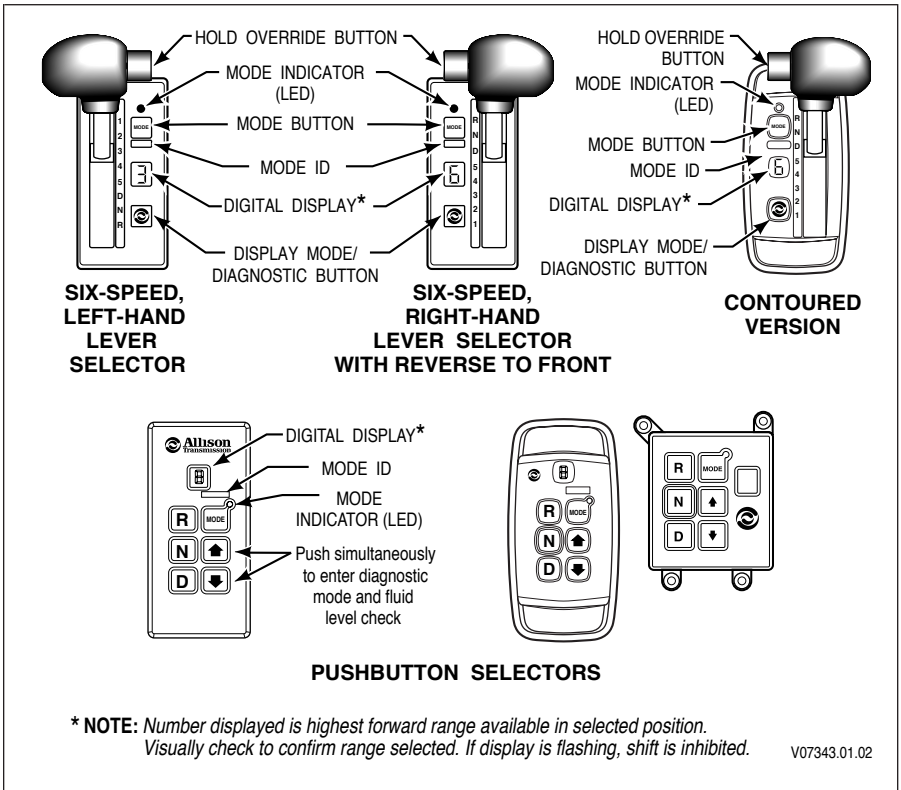

Figure 5. WTEC III Shift Selectors

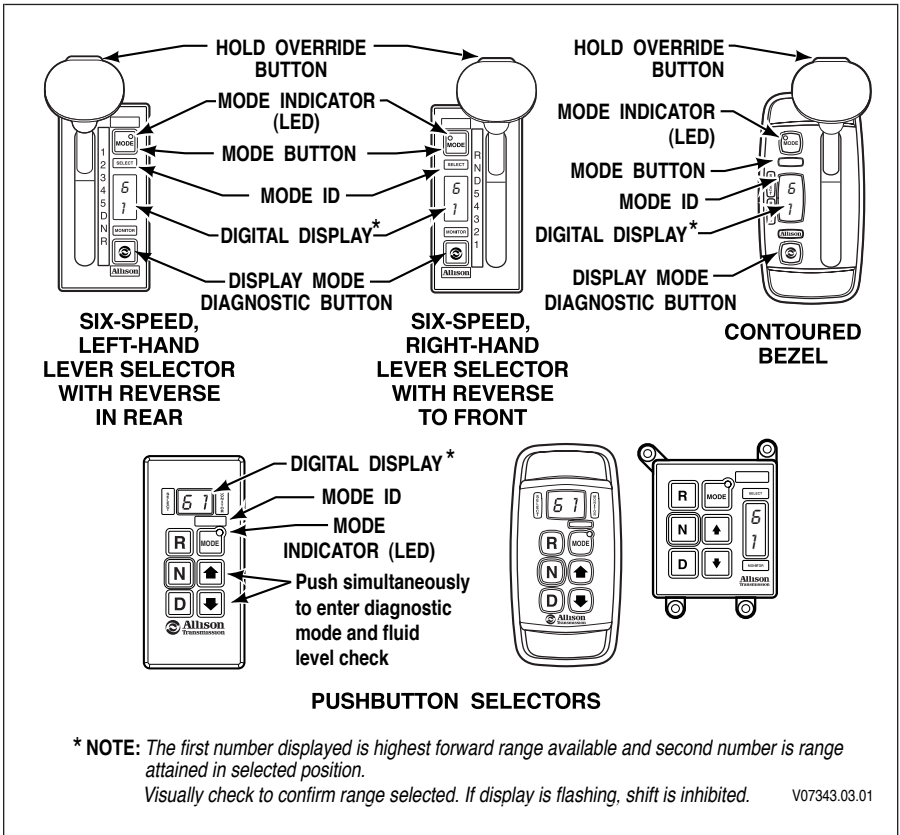

Figure 6. Allison 4th Generation Controls Shift Selectors

INTRODUCTION

Vehicle manufacturers may choose different types of shift selectors for their vehicles. The shift selector in your Allison-equipped vehicle will be similar to one of the pushbutton or lever styles shown above.

With an Allison-equipped vehicle, it is not necessary to select the right moment to upshift or downshift during changing road and traffic conditions. The Allison Motorhome Series transmission does it for you. However, knowledge of the shift selector positions, available ranges, and when to select them, make vehicle control and your job even easier. Select lower ranges when descending long grades (with or without retarder) to reduce wear on service brakes. Refer to the Range Selection table at the end of this section for related information.

LEVER SHIFT SELECTOR

General Description. The lever shift selector (refer to Figure 5 and Figure 6) is an electro-mechanical control. Typical lever positions are:

- **R** (Reverse)
- **N** (Neutral)
- **D** (Drive)
- Some number of lower forward range positions

Motorhome Series transmissions can be programmed to have four, five, or six forward ranges. Shift selector positions should agree with the programming of the TCM/ECU unit.

The lever selector includes the following:

- **HOLD OVERRIDE** button
- **MODE** button
- Digital display
- **DISPLAY MODE/DIAGNOSTIC** button

HOLD OVERRIDE Button. The lever shift selector has three locked positions to prevent accidentally selecting **R** (Reverse), **N** (Neutral), or **D** (Drive). Select **R** (Reverse), **N** (Neutral), or **D** (Drive) by pressing the **HOLD OVERRIDE** button and moving the lever to the desired position. Once **D** (Drive) is selected, lower forward range positions may be selected without pressing the **HOLD OVERRIDE** button.

MODE Button. The **MODE** button can allow the driver to enable a secondary shift schedule, PTO, or other special functions that have been programmed into the TCM/ECU unit at the request of the OEM. For example, a motorhome OEM may have provided a secondary shift schedule for improved fuel economy. The name of the special function (ECONOMY) appears on the MODE ID label adjacent to the **MODE** button. Pressing the **MODE** button activates the ECONOMY shift schedule and illuminates the MODE INDICATOR (LED).

When the Diagnostic Display Mode has been entered, the **MODE** button is used to view and toggle through diagnostic code information. After viewing the first diagnostic code which appears in the digital display, press the **MODE** button to view the 2nd diagnostic code logged. Repeat this procedure to view the 3rd, 4th, and 5th code positions. The code displayed is active if the MODE INDICATOR (LED) is illuminated.



NOTE: Visually check the digital display whenever the lever is moved to be sure the range selected is shown. **N** should appear in the digital display if the **N** (Neutral) button is pressed.

Digital Display. During normal operation, if **D** (Drive) is selected, the digital display shows the highest forward range attainable for the shift schedule in use.

Abnormal operation is indicated by the WTEC III digital display as follows:

- When all segments of the digital display are illuminated for more than 12 seconds, the ECU did not complete initialization.
- When the digital display is blank, there is no power to the selector.
- When the display shows a “\” (caterpillar), a selector-related fault code has been logged.
- Conditions which illuminate the **CHECK TRANS** light disable the shift selector and the digital display displays the range actually attained. For a detailed explanation, refer to the **CHECK TRANS LIGHT** paragraph in the **DRIVING TIPS** section.

Abnormal operation is indicated by the Allison 4th Generation Controls digital display as follows:

- When all segments of the digital display are illuminated, the shift selector did not complete initialization.
- When both digital displays remain blank for 10 seconds after initialization and then show a “\” (caterpillar), the shift selector is unable to communicate with the TCM or has experienced an internal fault.
- When the display shows a “\” (caterpillar), a selector-related fault code has been logged.
- Conditions which illuminate the **CHECK TRANS** light disable the shift selector. The **SELECT** digit is blank and the **MONITOR** digit displays the range actually attained. For a detailed explanation, refer to the **CHECK TRANS LIGHT** paragraph in the **DRIVING TIPS** section.

The transmission will not shift into range if a **CHECK TRANS** code is active. When the display shows **R** or **D** has been requested and the display is flashing, the requested range has not been achieved due to an inhibit function.

Some inhibit functions are vehicle-related and do not result in diagnostic codes. Some examples are mentioned in the Range Selection tables at the end of this Section.

Check for active codes if no other inhibit function has been located. Once **D** (Drive) is attained, the transmission will shift into the lowest range programmed for the **D** (Drive) position, usually first-range.

Display Mode/Diagnostic Button. The **DISPLAY MODE/DIAGNOSTIC** button allows access to optional fluid level check information and diagnostic code information. Press the **DISPLAY MODE/DIAGNOSTIC** button once to obtain transmission fluid level information and a second time to obtain diagnostic code information.

PUSHBUTTON SHIFT SELECTOR

General Description. The pushbutton shift selector (refer to Figure 5 and Figure 6) has the following:

- **R (Reverse)**—Press this button to select Reverse.
- **N (Neutral)**—Press this button to select Neutral.
- **D (Drive)**—Press this button to select Drive. The highest forward range available will appear in the digital display window. The transmission will start out in the lowest available forward range and advance automatically to the highest range.
- **↑ (Up) Arrow**—Press the ↑ (Up) Arrow when in **DRIVE** to request the next higher range. Continuously pressing the ↑ (Up) Arrow will request the highest range available.
- **↓ (Down) Arrow**—Press the ↓ (Down) Arrow when in **DRIVE** to request the next lower range. Continuously pressing the ↓ (Down) Arrow will request the lowest range available.
- **MODE Button and Display Mode/Diagnostic Button**—This is the same function as described previously in the LEVER SHIFT SELECTOR paragraph, **MODE Button** paragraph.



NOTE: The oil level sensor is a standard feature on Motorhome Series transmissions. Fluid level information is displayed after pressing both the ↑ (Up) and ↓ (Down) arrow buttons simultaneously. Simultaneously press both buttons again to obtain diagnostic data.

Refer to the Care And Maintenance section, FLUID LEVEL CHECK USING PUSHBUTTON OR LEVER SHIFT SELECTOR for more information about fluid level data. Refer to the Driving Tips section, DIAGNOSTIC CODES and DIAGNOSTIC CODE DISPLAY PROCEDURE, for more information about diagnostic codes and display procedure.

RANGE SELECTION

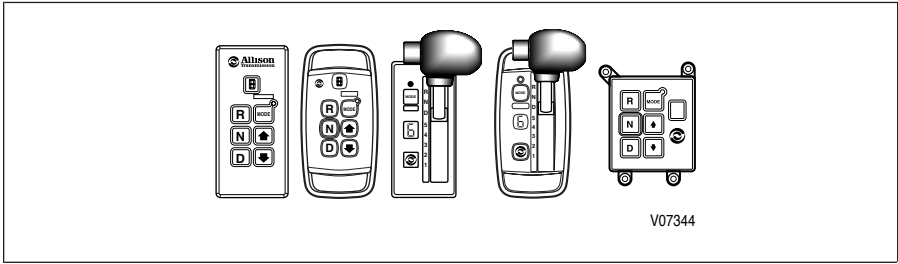

Figure 7. Typical Motorhome Series Shift Selectors (WTEC III Controls)

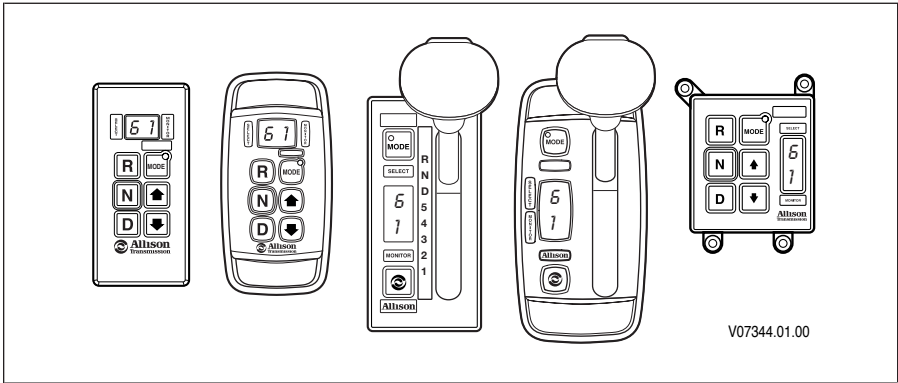









Figure 8. Typical Motorhome Series Shift Selectors (Allison 4th Generation Controls)





PUSHBUTTON AND LEVER SHIFT SELECTORS WITH DIGITAL DISPLAY

Description of Available Ranges (refer to Figure 7 and Figure 8)	
	<p>WARNING: If you leave the vehicle and the engine is running, the vehicle can move unexpectedly and you or others could be injured. If you must leave the engine running, do not leave the vehicle until you have completed all of the following procedures:</p> <ol style="list-style-type: none"> 1. Put the transmission in N (Neutral). 2. Be sure the engine is at low idle (500–800 rpm). 3. Apply the parking brakes and emergency brake and make sure they are properly engaged. 4. Chock the wheels and take any other steps necessary to keep the vehicle from moving.
	<p>WARNING: R (Reverse) may not be attained due to an active inhibitor. Always apply the service brakes when selecting R (Reverse) to prevent unexpected vehicle movement and because a service brake inhibit may be present. When “R” is flashing, it indicates the shift to R (Reverse) is inhibited. Check for active diagnostic codes if R (Reverse) is not attained. See DOWNSHIFT AND DIRECTION CHANGE INHIBITOR FEATURE in the DRIVING TIPS section.</p>
	<p>CAUTION: Do not idle in R (Reverse) for more than five minutes. Extended idling in R (Reverse) can cause transmission overheating and damage. Always select N (Neutral) whenever time at idle exceeds five minutes.</p>
	<p>NOTE: Visually check the digital display window whenever a button is pushed or the lever is moved to be sure the range selected is shown (i.e., if the N (Neutral) button is pressed, “N” should appear in the digital display). A flashing display indicates the range selected was not attained due to an active inhibit.</p>

**PUSHBUTTON AND LEVER SHIFT SELECTORS
WITH DIGITAL DISPLAY (cont'd)**

Description of Available Ranges (refer to Figure 7 and Figure 8)	
R	Completely stop the vehicle and let the engine return to idle before shifting from a forward range to R (Reverse) or from R (Reverse) to a forward range. The digital display will display “ R ” when R (Reverse) is selected.
	WARNING: When starting the engine, make sure the service brakes are applied. Failure to apply the service brakes can result in unexpected vehicle movement.
	Vehicle service brakes, parking brake, or emergency brake must be applied whenever N (Neutral) is selected to prevent unexpected vehicle movement. Selecting N (Neutral) does not apply vehicle brakes, unless an auxiliary system to apply the parking brake is installed (see the Operator’s Manual for the vehicle).
	WARNING: If you let the vehicle coast in N (Neutral), there is no engine braking and you could lose control. Coasting can also cause severe transmission damage. To help avoid injury and property damage, do not allow the vehicle to coast in N (Neutral).
N	Use N (Neutral) when starting the engine, to check vehicle accessories, and for extended periods of engine idle operation (longer than five minutes). For vehicles equipped with the pushbutton selector, N (Neutral) is selected by the ECU during start-up. For vehicles equipped with the lever selector, the vehicle will not start unless N (Neutral) has been selected. If the vehicle starts in any range other than N (Neutral), seek service immediately. N (Neutral) is also used during stationary operation of the power takeoff (if the vehicle is equipped with a PTO). The digital display will show “ N ” when N (Neutral) is selected. Always select N (Neutral) before turning off the vehicle engine.

PUSHBUTTON AND LEVER SHIFT SELECTORS WITH DIGITAL DISPLAY *(cont'd)*

Description of Available Ranges (refer to Figure 7 and Figure 8)	
	<p>WARNING: D (Drive) may not be attained due to an active inhibitor. Always apply the service brakes when selecting D (Drive) to prevent unexpected vehicle movement and because a service inhibit may be present. When “D” is flashing, it indicates the shift to D (Drive) is inhibited. Check for active diagnostic codes if D (Drive) is not attained. See DOWNSHIFT AND DIRECTION CHANGE INHIBITOR FEATURE in the DRIVING TIPS section.</p>
	<p>CAUTION: Do not idle in D (Drive) or any forward range for more than five minutes. Extended idling in D (Drive) can cause transmission overheating and damage. Always select N (Neutral) whenever time at idle exceeds five minutes.</p>
	<p>NOTE: Turn off the vehicle HIGH IDLE switch, if present, before shifting from N (Neutral) to D (Drive) or R (Reverse). D (Drive) or R (Reverse) will not be attained unless the shift is made with the engine at idle. Also, be aware of other interlocks that would prevent attaining D (Drive) or R (Reverse). Examples are “wheelchair lift not stored” and “service brakes not applied” (service brake interlock present).</p>
D	<p>The transmission will initially attain first-range when D (Drive) is selected (except for those units programmed to start in second-range). As vehicle speed increases, the transmission will upshift automatically through each range. As the vehicle slows, the transmission will downshift automatically through each range. The digital display will show the highest range available in D (Drive).</p>
	<p>WARNING: The transmission incorporates a hold feature to prohibit upshifting above the range selected during normal driving. For downhill operation, select a lower transmission range. If the engine governed speed is exceeded in the held range, however, the transmission will upshift to the next higher range to prevent engine damage. To avoid injury and/or property damage due to loss of vehicle control, use the vehicle brakes to prevent exceeding engine governed speed in the held range.</p>

**PUSHBUTTON AND LEVER SHIFT SELECTORS
WITH DIGITAL DISPLAY (cont'd)**

Description of Available Ranges (refer to Figure 7 and Figure 8)	
<p>6* 5* 4* 3 2</p>	<p>Lower ranges provide greater engine braking for going down grades (the lower the range, the greater the braking effect). Occasionally, it may be desirable to restrict automatic shifting to a lower range because of:</p> <ul style="list-style-type: none"> • Road conditions. • Load. • Traffic conditions. • Etc. <p>The pushbutton shift selector arrow buttons access individual forward ranges. Push the ↑ (Up) or ↓ (Down) arrow for the desired range. The digital display shows the range chosen. Even though a lower range is selected, the transmission may not downshift until vehicle speed is reduced (this prevents excessive engine speed in the lower range).</p>
1	<p>First-range provides the vehicle with its maximum driving torque and engine braking effect. Use first-range when:</p> <ul style="list-style-type: none"> • Pulling through mud and deep snow. • Maneuvering in tight spaces. • Driving up or down steep grades. <p>For vehicles equipped with the pushbutton selector, push the ↓ (Down) arrow until first-range appears in the select window.</p>
<p>* Actual ranges available depend on programming by vehicle manufacturer.</p>	

MOTORHOME SERIES

DRIVING TIPS

CHECK TRANS LIGHT

The electronic control system is programmed to inform the operator of a problem with the transmission system and automatically take action to protect the operator, vehicle, and transmission. When the Electronic Control Unit (ECU) or the Transmission Control Module (TCM) detects a problem condition, the TCM/ECU:

- Restricts shifting.
- Illuminates the **CHECK TRANS** light on the instrument panel.
- Registers a diagnostic code.



NOTE: For some problems, diagnostic codes may be registered without the TCM/ECU activating the **CHECK TRANS** light. Your Allison Transmission authorized service outlet should be consulted whenever there is a transmission-related concern. They have the equipment to check for diagnostic codes and to correct problems which arise.

Each time the engine is started, the **CHECK TRANS** light will illuminate, then turn off after a few seconds. This momentary lighting is to show that the status light circuits are working properly. If the **CHECK TRANS** light does not illuminate during ignition, or if the light remains on after ignition, the system should be checked immediately.

Continued illumination of the **CHECK TRANS** light during vehicle operation (other than start-up) indicates that the TCM/ECU has signaled a diagnostic code. Illumination of the **CHECK TRANS** light is accompanied by a flashing display from the shift selector. The shift selector display will show the actual range attained and the transmission will not respond to shift selector requests.

Indications from the shift selector are provided to inform the operator the transmission is not performing as designed and is operating in the “limp home” mode with reduced capabilities. Before turning off the ignition, the transmission may be operated for a short time in the selected range in order to “limp home” for

service assistance. Service should be performed immediately in order to minimize the potential for damage to the transmission.

When the **CHECK TRANS** light comes on and the ignition switch is turned off, the transmission will remain in **N** (Neutral) until the condition causing the **CHECK TRANS** light is corrected.

Generally, while the **CHECK TRANS** light is on, upshifts and downshifts will be restricted and **direction changes will not occur**. Lever and pushbutton shift selectors **do not respond** to any operator shift requests while the **CHECK TRANS** light is illuminated. The lockup clutch is disengaged when transmission shifting is restricted or during any critical transmission malfunction.

DIAGNOSTIC CODES

See detailed information in the DIAGNOSTICS section.

ACCELERATOR CONTROL



WARNING: To help avoid injury or property damage caused by sudden movement of the vehicle, do not make shifts from **N** (Neutral) to **D** (Drive) or **R** (Reverse) when the throttle pedal is depressed. If you shift while the throttle pedal is depressed too far, the transmission will only engage if the throttle pedal is released in the next three seconds. This may cause a sudden movement of the vehicle. Leaving the throttle pedal depressed longer than three seconds causes the transmission to remain in **N** (Neutral). Avoid this condition by making shifts from **N** (Neutral) to **D** (Drive) or **R** (Reverse) only when the throttle is closed.

The position of the accelerator pedal influences when automatic shifting occurs. An electronic throttle position signal tells the TCM/ECU how much the operator has depressed the pedal. When the pedal is fully depressed, upshifts will occur automatically at high engine speeds. A partially depressed position of the pedal will cause upshifts to occur at lower engine speeds. Excessive throttle position affects directional changes—shifts from **N** (Neutral) to **D** (Drive) or **R** (Reverse).

DOWNSHIFT AND DIRECTION CHANGE INHIBITOR FEATURE



NOTE: Turn off the vehicle **HIGH IDLE** switch, if present, before shifting from **N** (Neutral) to **D** (Drive) or **R** (Reverse). The shift from **N** (Neutral) to **D** (Drive) or **R** (Reverse) is inhibited when engine speed is above idle.

There is no speed limitation on upshifting, but there is a limitation on downshifting and for shifts that cause a direction change such as **D** (Drive)-to-**R** (Reverse) or **R** (Reverse)-to-**D** (Drive).

Manual range downshifts will not occur until a calibration output speed (preset) is reached. When a range downshift is manually selected and the transmission output speed is above the calibration speed, the transmission will stay in the range it was in even though a lower range was requested. Apply the vehicle service brakes or a retarding device to reduce the transmission output speed to the calibration speed and then the shift to the lower range will occur.

Directional shifts, **D** (Drive)-to-**R** (Reverse) or **R** (Reverse)-to-**D** (Drive), will not occur if selected when throttle position, engine speed, or transmission output speed is above the calibration limit for a calibration time period. The current calibration time period for engine speed is 0.5 seconds and for throttle position and output speed is three seconds.

Shifts from **N** (Neutral)-to-**D** (Drive) or **N** (Neutral)-to-**R** (Reverse) are also inhibited when the TCM/ECU has been programmed (by input/output function) to detect that auxiliary equipment is in operation and the shift should not be allowed.

When directional change shifts are inhibited, the TCM/ECU will put the transmission in **N** (Neutral) and the digital display, if present, will flash the letter of the range selected (D or R). To reselect **D** (Drive) or **R** (Reverse) when engine throttle, engine speed, and transmission output speed are below the calibration value:

- Pushbutton selector—Press the desired pushbutton again.
- Lever selector—Move the lever to **N** (Neutral) and then to the desired range.

When a direction change shift is requested and engine throttle, engine speed, and transmission output speed drop below the calibration value during the calibration time interval, the shift to **D** (Drive) or **R** (Reverse) will occur.

- For example, if the transmission output speed was just above the calibration limit when **R** (Reverse) was selected, but dropped below the limit during the next three seconds, the shift to **R** (Reverse) would occur (assuming the engine was at idle and the throttle was closed).

USING THE ENGINE TO SLOW THE VEHICLE



WARNING: To avoid loss of control, use a combination of downshifting, braking, and other retarding devices. Downshifting to a lower transmission range increases engine braking and can help you maintain control. The transmission has a feature to prevent automatic upshifting above the lower range selected. However, during downhill operation, if engine governed speed is exceeded in the lower range, the transmission will upshift to the next higher range to prevent engine damage. This will reduce engine braking and could cause a loss of control. Apply the vehicle brakes or other retarding device to prevent exceeding engine governed speed in the lower range selected.

Engine braking provides good speed control for going down grades. When the vehicle is heavily loaded, or the grade is steep, it may be desirable to preselect a lower range before reaching the grade. If engine-governed speed is exceeded, the transmission will upshift automatically to the next range.

To use the engine as a braking force, select the next lower range. If the vehicle is exceeding the maximum speed for this range, use the service brakes and/or retarder to slow the vehicle. When a lower speed is reached, the TCM/ECU will automatically downshift the transmission.

USING THE HYDRAULIC RETARDER



WARNING: DO NOT USE THE RETARDER DURING INCLEMENT WEATHER OR WHEN ROAD SURFACES ARE SLIPPERY.

De-energize the retarder at the master control switch.

To help avoid injury or property damage caused by loss of vehicle control, be ready to apply vehicle brakes or other retarding device if the transmission retarder does not apply. If a retarder is present but is not detected by “autodetect”, the retarder will not function. Be sure to check for proper retarder function periodically. Whenever the retarder does not apply, seek service help immediately.

On vehicles which have the primary retarder control based upon closed throttle position, brake pedal position, or brake apply pressure, always manually disable the retarder controls during inclement weather or slippery road conditions.

Regardless of the type of Allison retarder controls on your vehicle, the following safety features are common to each configuration:

- The retarder can be disabled when inclement weather or slippery road conditions are present.

- Vehicle brake lights should always be on when the retarder is applied (periodically verify that they are working).
- Anti-lock brake systems send a signal to the transmission TCM/ECU to indicate that the brake system is activated.



NOTE: The retarder is automatically disabled and the lockup clutch is disengaged whenever the vehicle anti-lock brake system (ABS) is active. However, in case the ABS system malfunctions, it is recommended that the retarder enable switch, if present, be disabled.

A hydraulic retarder is available on all of the models covered in this manual. The retarder is activated and controlled in various ways. The control depends upon the vehicle type and particular duty cycle. Both manual and automatic controls are available. Automatic controls are applied by the TCM/ECU. In Allison 4th Generation Control Systems, the TCM may also activate or limit retarder operation in response to torque speed control or electronic retarder control messages received on the vehicle's J1939 Data Link. Some types of controls and the amount of retarder application are shown in the Types of Retarder Control table that follows.

The presence of a retarder must be "autodetected" as part of Allison 4th Generation Controls and the WTEC III control system.



NOTE: If your transmission has a retarder but it is not functioning, it may not have been "autodetected" during vehicle manufacture. Go immediately to your nearest Allison Transmission service outlet to have "autodetect" reset or the retarder enabled using the Allison DOC™ For PC-Service Tool.



NOTE: When reduced retarder performance is observed, be sure the transmission fluid level is within the operating band on the dipstick (refer to Figure 11). Low fluid level is a common cause for retarder performance complaints.



NOTE: The retarder requires about one second to reach full capacity requested. Be sure to anticipate this delay when using the retarder. Anticipation will prevent unnecessary service brake applications during non-emergency stops.

Types of Retarder Control

Type	Description	Amount of Application
Manual	Separate apply pedal	Zero to Full apply
	Hand lever *	Six levels based on lever position
Automatic	Auto “Full On” *	“Full On” when closed throttle sensed
Brake Pressure Apply**	Single pressure switch	Off or “Full On” (based on brake pressure)
	Three pressure switches	$\frac{1}{3}$, $\frac{2}{3}$, or “Full On” (based on brake pressure)
Pedal Position **	Special brake pedal	$\frac{1}{3}$, $\frac{2}{3}$, or “Full On” (based on pedal position)
J1939 Data Link	Digital message from engine controller	Zero to Full Apply
Combinations of the above systems **	Auto “half-on” plus pressure switch *	Half capacity at closed throttle or “Full On” with brake pressure
	Auto “ $\frac{1}{3}$ on” plus two pressure switches *	$\frac{1}{3}$, capacity at closed throttle or $\frac{2}{3}$ and “Full On” with brake pressure
	Hand lever plus pressure switch *	6 levels of modulation with lever, or “Full On” with brake pressure
	Foot pedal plus pressure switch	Full modulation with separate pedal, or “Full On” with brake pressure
	Hand lever plus interface for special pedal *	6 levels of modulation with lever, or 3 levels of modulation based on pedal position
<p>* These control systems may apply the retarder at high speed on grades when the vehicle has road speed limiting and the retarder is enabled.</p> <p>** For retarder apply systems integrated with the service brake system, the retarder is most effective when applied with light brake pedal pressure for 1–2 seconds to allow the retarder to fully charge. Added pedal pressure can be applied when more aggressive braking is desired.</p>		



NOTE: When the transmission fluid or engine water temperature (engine water is an OEM option) exceeds programmed limits, retarder capacity is automatically gradually reduced to minimize or avoid possible system overheating.

Contact your vehicle manufacturer to understand how the retarder controls have been integrated into your vehicle.



CAUTION: Observe the following cautions when driving a vehicle equipped with a retarder:

- **THE RETARDER WORKS ONLY WHEN THE ENGINE IS AT CLOSED THROTTLE.**
- **OBSERVE TRANSMISSION AND ENGINE TEMPERATURE LIMITS AT ALL TIMES.** Select the lowest possible transmission range to increase the cooling system capacity and total retardation available.
- **In the event of OVERHEATING, DECREASE THE USE OF THE RETARDER; USE THE SERVICE BRAKES TO SLOW THE VEHICLE.**
- **OBSERVE THE RETARDER/SUMP “OVERTEMP” LIGHT** to be sure it responds properly to retarder temperature.



NOTE: Transmission fluid level must be set correctly for highest retarder effectiveness. As much as 2 liters (2 quarts) too high or too low can reduce retarder effectiveness and increase transmission temperature.

ADAPTING SHIFTS

When poor shift quality is due to the installation of a new or recalibrated ECU, use the following procedure to restore good shift quality by completing a prescribed number of shifts in a relatively short time instead of over several days of operation.



NOTE: Shift concerns may indicate the transmission has never had the shifts fully adapted.

The adaptive feature does not function below 100°F transmission sump temperature. Normal sump temperature is recommended before this procedure is followed.

Check transmission sump level and assure it is set to “Hot Full” at normal sump temperature before this procedure is followed.

All segments of this procedure are to be repeated a **minimum of 5 times** or until shift quality variation is indistinguishable from shift to shift.

1. From Neutral, with parking brake set and service brakes applied via foot pedal, select the following sequence: Drive, Neutral, Reverse, Neutral, Drive, Reverse, Drive, Neutral. Allow each shift to fully complete before selecting the next shift.
2. Release all brakes and perform this sequence: Wide Open Throttle (WOT) 1–2; once shift is complete, release the throttle to closed and decelerate to just prior to the Closed Throttle (CT) 2–1 and perform a Step Thru (ST) 2–1 by going to WOT.
3. Continue the process initiated in Step 2 for each Upshift and Downshift combination available. Example: Wide Open Throttle (WOT) 2–3; once shift is complete, release the throttle to closed and decelerate to just prior to the Closed Throttle (CT) 3–2 and perform a Step Thru (ST) 3–2 by going to WOT. Repeat for the WOT 3–4/ST 4–3, WOT 4–5/ST 5–4, WOT 5–6/ST 6–5.
4. From a Stop, release vehicle brakes and perform a set of Part Throttle (PT—50 to 60 percent) Upshifts to the highest attainable range for the vehicle. Release the throttle to closed and use light vehicle brakes to decelerate to a stop.



NOTE: If the vehicle is equipped with an output retarder or engine brake system, these systems should be turned off for this segment.

5. From a Stop, release vehicle brakes and perform Part Throttle (PT—50 to 60 percent) Upshifts to the 3rd range. Release the throttle to closed and, using moderate to heavy vehicle brakes (NOT panic or wheel lock), decelerate to a stop.



NOTE: Braking should be aggressive but not to the level that would cause passenger complaints. If the vehicle is equipped with an output retarder or engine brake system, these systems should be turned off for this segment.

6. From a Stop, release vehicle brakes and perform a set of Wide Open Throttle Upshifts to the highest attainable range for the vehicle. Release the throttle to Closed and Preselect Down to 1st Range using the shift selector. Use light vehicle brakes to decelerate to a stop.
7. If the vehicle is equipped with a retarder or engine brake, turn that system on for this segment. From a Stop, release vehicle brakes and perform a set of Wide Open Throttle Upshifts to the highest attainable range for the vehicle. Release the throttle to Closed and, using light vehicle brakes and the retarder or engine brake, decelerate vehicle to a stop.



NOTE: Allison Transmission does not recommend using the vehicle brakes to “force” Powered Downshifts (PD, downshifts with the throttle applied). If grades are available, these should be used to adapt in WOT and PT Powered Downshifts.

8. Approach the grade in the highest safely attainable range and hold the throttle steady at WOT and allow the vehicle to perform the Powered Downshifts as required to ascend the grade.
9. Approach the grade in the highest safely attainable range and hold the throttle steady at Part Throttle (PT—50 to 60 percent) and allow the vehicle to perform the Powered Downshifts as required to ascend the grade.

RANGE PRESELECTION



NOTE: Preselecting during normal operation may result in reduced fuel economy.

Range preselection means selecting a lower range to match driving conditions encountered or expect to be encountered. Learning to take advantage of preselected shifts will give you better control on slick or icy roads and on downgrades.

Downshifting to a lower range increases engine braking. The selection of a lower range often prevents cycling between that range and the next higher range on a series of short up-and-down hills.

COLD WEATHER STARTS

All Motorhome Series transmissions are programmed to restrict full operation until specific fluid temperatures are reached. Refer to the following table for temperature restrictions.

Minimum Fluid Operating Temperatures

Sump Fluid Temperature	CHECK TRANS Light	Operation
-32°C (-25°F) to -7°C (19°F)	OFF	Neutral, Reverse, Second
-7°C (19°F)	OFF	Full operation in all ranges



NOTE: When sump temperature is below 10°C (50°F) and transmission fluid is C4 (**not DEXRON® or TranSynd™**), follow these procedures when making directional shift changes:

- To shift from forward to reverse, select **N** (Neutral) and then **R** (Reverse).
- To shift from reverse to forward, select **N** (Neutral) and then **D** (Drive) or other forward range.

Failure to follow these procedures may cause illumination of the **CHECK TRANS** light and the transmission will be restricted to **N** (Neutral).

Transmission operation at cold ambient temperatures may require preheating or the use of a lower viscosity transmission fluid. Refer to **RECOMMENDED AUTOMATIC TRANSMISSION FLUID AND VISCOSITY GRADE** in the Care And Maintenance section.

DRIVING ON SNOW OR ICE



WARNING: Using the retarder on wet or slippery roads may cause loss of traction on the drive wheels—your vehicle may slide out of control. To help avoid injury or property damage, turn the retarder enable to **OFF** when driving on wet or slippery roads.



NOTE: The retarder is automatically disabled whenever the vehicle ABS is active. However, in case the anti-lock brake system (ABS) malfunctions, it is recommended that the retarder enable switch, if present, be disabled.

If possible, reduce vehicle speed and select a lower range before losing traction. Select the range that will not exceed the speed expected to be maintained.

Accelerate or decelerate very gradually to prevent the loss of traction. It is very important to decelerate gradually when a lower range is selected. It is important that you reach the selected lower range before attempting to accelerate. This will avoid an unexpected downshift during acceleration.

ROCKING OUT



WARNING: To help avoid injury or property damage caused by sudden movement of the vehicle, do not make shifts from **N** (Neutral) to **D** (Drive) or **R** (Reverse) when the throttle is open. The vehicle will lurch forward or rearward and the transmission can be damaged. Avoid this condition by making shifts from **N** (Neutral) to a forward range or **R** (Reverse) only when the throttle is closed and the service brakes are applied.



CAUTION: DO NOT make **N** (Neutral) to **D** (Drive) or directional shift changes when the engine rpm is above idle. Also, if the wheels are stuck and not turning, do not apply full power for more than 10 seconds in either **D** (Drive) or **R** (Reverse). Full power for more than 10 seconds under these conditions will cause the transmission to overheat. If the transmission overheats, shift to **N** (Neutral) and operate the engine at 1200–1500 rpm until it cools (2–3 minutes).

If the vehicle is stuck in deep sand, snow, or mud, it may be possible to rock it out using the following procedure:

1. Shift to **D** (Drive) and apply steady, light throttle (**never full throttle**).
2. When the vehicle has rocked forward as far as it will go, apply and hold the vehicle service brakes.
3. When engine has returned to idle, select **R** (Reverse).
4. Release the brakes and apply a steady, light throttle allowing the vehicle to rock in **R** (Reverse) as far as it will go.
5. Again, apply and hold the service brakes and allow the engine to return to idle.

This procedure may be repeated in **D** (Drive) and **R** (Reverse) if each directional shift continues to move the vehicle a greater distance. **Never** make **N** (Neutral)-to-**D** (Drive) or directional shift changes when the engine rpm is above idle.

HIGH FLUID TEMPERATURE

The transmission is considered to be overheated when any of the following temperatures are exceeded:

Sump fluid	121°C (250°F)
Fluid to cooler	149°C (300°F)
Retarder out fluid	165°C (330°F)

If the transmission overheats during normal operations, check the fluid level in the transmission. Refer to the fluid level check procedures described in the CARE AND MAINTENANCE section.



CAUTION: The engine should never be operated for more than 10 seconds at full throttle with the transmission in range and the output stalled. Prolonged operation of this type will cause the transmission fluid temperature to become excessively high and will cause severe overheating damage to the transmission.

If the engine temperature gauge indicates a high temperature, the transmission is probably overheated. Stop the vehicle and check the cooling system. If it appears to be functioning properly, run the engine at 1200–1500 rpm with the transmission in **N** (Neutral). This should reduce the transmission and engine temperatures to normal operating levels in 2 or 3 minutes. If temperatures do not decrease, reduce the engine rpm.

If the engine temperature indicates a high temperature, an engine or radiator problem is indicated. If high temperature in either the engine or transmission persists, stop the engine and have the overheating condition investigated by maintenance personnel.

PARKING BRAKE



WARNING: If you leave the vehicle and the engine is running, the vehicle can move unexpectedly and you or others could be injured. If you must leave the engine running, **DO NOT LEAVE** the vehicle until you have completed all of the following procedures:

- Put the transmission in **N** (Neutral).
- Be sure the engine is at low idle (500–800 rpm).
- Apply the parking brake and emergency brake and make sure they are properly engaged.
- Chock the wheels and take other steps necessary to keep the vehicle from moving.

The parking brake is only intended to secure an unattended vehicle with the engine ignition **OFF**. Always maintain the vehicle parking brake system according to the manufacturer's specifications. The parking brake may not have sufficient capacity to restrain a vehicle with the engine running and the transmission in a forward or reverse-range. When the vehicle is unattended and the engine is in operation, the transmission **must be in N** (Neutral) with the **brakes fully applied** and the **wheels chocked**.

TOWING OR PUSHING



CAUTION: Failure to lift the driving wheels off the road, disconnect the driveline, or remove the axle shafts before pushing or towing can cause serious transmission damage.

The engine cannot be started by pushing or towing. Before pushing or towing a vehicle do one of the following:

- Disconnect the driveline.
- Lift the drive wheels off the road.
- Remove the axle shafts from the drive wheels.

An auxiliary air supply will usually be required to actuate the vehicle brake system.

When the axle shafts are removed, be sure to cover the wheel openings to prevent loss of lubricant and entry of dust and dirt.

PRIMARY/SECONDARY SHIFT SCHEDULES

The points at which shifts occur depend upon predetermined speeds and other operating conditions. A transmission “shift calibration” includes several sets of shift points which may be used according to current or anticipated operating conditions. Some shift schedules may be inhibited as a result of operating conditions, such as engine or transmission fluid temperature. Shift schedules may be changed using the **MODE** button (some applications may use a dash-mounted switch)—which is typically associated with a change in anticipated vehicle operation.

The TCM includes the capacity for two separate and distinct shift calibrations (customer-selectable), one for use in “Primary Mode” of operation and one in “Secondary Mode.”

- **Primary**—This shift schedule is typically used for all normal vehicle operations.
- **Secondary**—This is an alternate shift schedule that the TCM uses upon request. Not all vehicles will be equipped with a secondary shift schedule. The request can be interlocked with a vehicle component, or be operator-controlled using the **MODE** button.

Your vehicle may have a dash-mounted light that illuminates when the secondary mode is active.

CRUISE CONTROL OPERATION

Operating an Allison WTEC III Controls or Allison 4th Generation Controls-equipped vehicle on cruise control may cause the transmission to shift

cycle if the cruise control speed setting is set too close to a scheduled shift point. One of the following actions may eliminate shift cycling:

- Select the secondary shift schedule by pushing the **MODE** button (refer to Figure 5 or Figure 6) on the shift selector.
- Select a lower range by pushing the ↓ (Down) arrow or moving the lever on the shift selector.
- Change the cruise control setting away from the shift point.

Some vehicles equipped with an engine brake and an Allison WTEC III Controls or Allison 4th Generation Controls-equipped transmission will have the engine brake controlled by the TCM/ECU. This is done so the transmission will automatically select a lower range when the engine brake is turned on and the throttle is near idle position.

Operating a vehicle on cruise control with the engine brake turned on and controlled by the transmission TCM/ECU, may cause an unwanted application of the engine brake when the cruise control decelerates for downhill grades. Eliminate this condition by turning off the engine brake while operating the vehicle on cruise control.

TURNING OFF THE VEHICLE

Always select **N** (Neutral) prior to turning off the vehicle engine.

MOTORHOME SERIES

POWER TAKEOFF OPERATION

ENGINE-DRIVEN POWER TAKEOFF (PTO)



CAUTION: Do not exceed the engagement and operational speed limits imposed on the driven equipment during the operation of the PTO. Exceeding the speed limits produces high hydraulic pressure in the PTO that can damage the PTO components. Consult the vehicle manufacturer's literature for these speed limits.

If a PTO is present, it will be mounted on either the left side or the right side for a 3000 MH transmission depending upon the converter housing configuration. The PTO is located on the left side or top for a 4000 MH Series transmission. The PTO drive gear is engine-driven and therefore provides direct engine power. The PTO can be operated when the vehicle is either moving or stopped.

The PTO gear is in constant mesh with the drive gear in the converter housing. PTOs are either constant drive (output always powered) or clutched drive. The output of a clutched drive PTO is powered when the PTO clutch is pressurized.

Be sure that the limits for PTO engagement speed and operational speed are not exceeded. Consult the vehicle manufacturer's literature for these speed limits. Also, all Motorhome Series-equipped vehicles with PTO enable have engagement and operational speed limits programmed into the ECU to help protect PTO equipment. Some speed limits have default values which are programmed out of the operating range and will need to be set for your particular PTO duty cycle. Consult your vehicle manufacturer to see if your transmission has been programmed and what operational limits have been established.

When the programmed engagement speed is exceeded, the PTO will not engage. The PTO engagement must be retried after the speed has been reduced. When operational speeds (either engine or transmission output) are exceeded, the PTO will deactivate and the PTO engagement process must be repeated.

MOTORHOME SERIES

CARE AND MAINTENANCE

PERIODIC INSPECTIONS

Allison Motorhome Series transmissions require minimum maintenance. Careful attention to the fluid level and the connections for the electronic and hydraulic circuits is most important.

For easier inspection, the transmission should be kept clean. Make regular periodic inspections and check:

- For loose bolts.
- For leaking fluid around fittings, lines, and transmission openings.
- The condition of the electrical harnesses.
- The engine cooling system for presence of transmission fluid and check the transmission fluid for presence of coolant, which would indicate a faulty oil cooler.
- The breather (refer to Figure 1 through Figure 4) to make sure it is clean and free from dirt or debris.

Report any abnormal condition to your nearest Allison distributor or dealer.

PREVENT MAJOR PROBLEMS

Help Allison 4th Generation Controls or WTEC III Controls oversee the operation of the transmission. Minor problems can be kept from becoming major problems if an Allison Transmission distributor or dealer is notified when one of these conditions occur:

- Shifting feels odd.
- Transmission leaks fluid.
- Unusual transmission-related sounds (changes in sound caused by normal engine thermostatic fan cycling, while climbing a long grade with a heavy load, have been mistaken for transmission-related sounds).
- **CHECK TRANS** light comes on frequently.

IMPORTANCE OF PROPER FLUID LEVEL

It is important that the proper fluid level be maintained at all times because the transmission fluid cools, lubricates, and transmits hydraulic power. If the fluid level is too low, the converter and clutches do not receive an adequate supply of fluid. If fluid level is too high, the fluid can aerate. Aerated fluid can cause the transmission to shift erratically or overheat.

Motorhome Series transmissions have an oil level sensor (OLS) that allows the operator to obtain an indication of fluid level from the shift selector. However, no oil level sensor diagnostics take place unless the OLS is “autodetected” by Allison 4th Generation Controls or WTEC III Controls.

Frequently check for the presence of oil level diagnostics if the transmission is known to contain an OLS. If an OLS is not detected during a fixed number of engine starts, the WTEC III or Allison 4th Generation Controls system concludes that no OLS is present. If an OLS is known to be present, but has not been detected, then troubleshooting of the OLS circuit is required. After the OLS circuit is repaired, reset “autodetect” or manually select the OLS function using Allison DOC™ For PC–Service Tool. For detailed troubleshooting procedures refer to the Troubleshooting Manual. Refer to the SERVICE LITERATURE section for specific publication numbers.



NOTE: To correctly check the transmission fluid level using the dipstick, the transmission fluid must be at operating temperature.

The oil level sensor method of checking the fluid level compensates for transmission fluid temperature between 60°C–104°C (140°F–220°F). Any temperature below 60°C (140°F) or above 104°C (220°F) will result in an **Invalid for Display** condition.

FLUID LEVEL CHECK USING PUSHBUTTON OR LEVER SHIFT SELECTOR

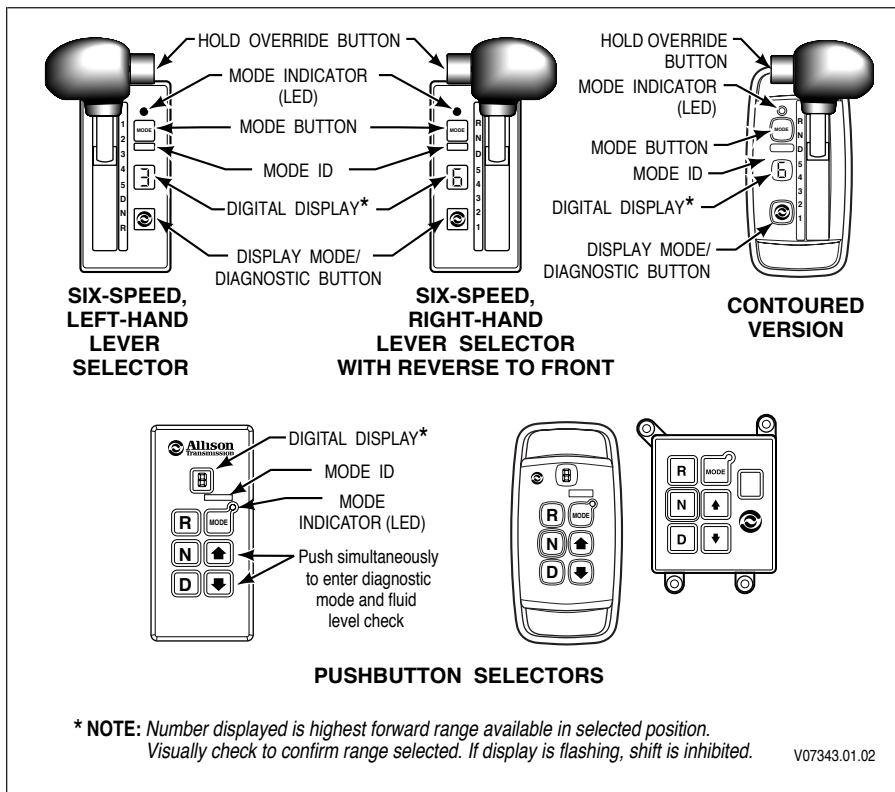

Figure 9. WTEC III Controls Shift Selectors and Pushbutton Selectors

The transmission must be equipped with the oil level sensor to be able to read fluid level information.



NOTE: WTEC III Controls pushbutton and lever selectors display fluid level diagnostic information one character at a time. Allison 4th Generation Controls pushbutton and lever selectors display fluid level diagnostic information two characters at a time.

1. Park the vehicle on a level surface, shift to **N** (Neutral), and apply the parking brake.
2. **Pushbutton shift selector**—If equipped with an oil level sensor, simultaneously press the ↑ (Up) and ↓ (Down) arrow buttons.

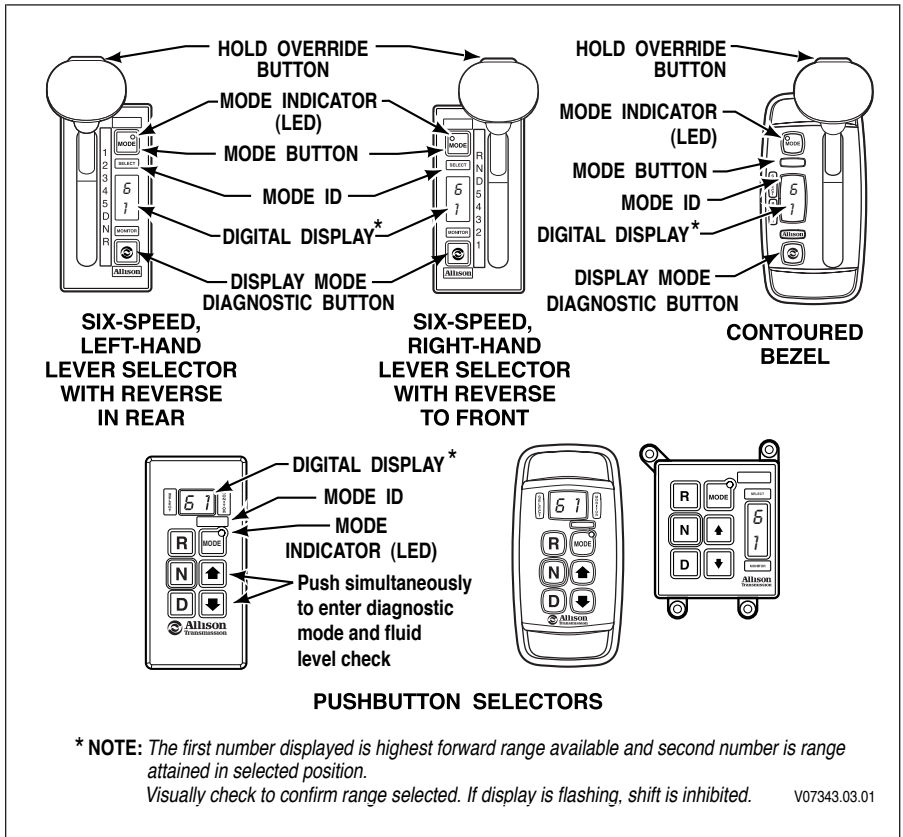

Figure 10. Allison 4th Generation Controls Shift Selectors and Pushbutton Selectors

3. **Lever shift selector**—If equipped with an oil level sensor, press the display mode button one time.



NOTE: The fluid level check may be delayed until the following conditions are met:

- The fluid temperature is above 60°C (140°F) and below 104°C (220°F).
- The transmission is in N (Neutral).
- The engine is at idle.
- The transmission output shaft is stopped.
- The vehicle has been stationary for approximately two minutes to allow the fluid to settle.

A delayed fluid level check for transmissions with WTEC III Controls is indicated by a “—” in the display window followed by a numerical countdown. The countdowns, starting at 8, indicates the time remaining in the two minutes setting period.

The indication of a delayed fluid level check for Allison 4th Generation Controls is a flashing display under **SELECT** and a digit countdown from 8 to 1 under **MONITOR**.

- **Correct Fluid Level**—“**o L**” is displayed (“**o L**” represents “Fluid (Oil) Level Check Mode”), followed by “**o K**”. The “**o K**” display indicates the fluid is within the correct fluid level zone. The sensor display and the transmission dipstick may not agree exactly because the oil level sensor compensates for fluid temperature.



NOTE: WTEC III Controls displays fluid level diagnostic information one character at a time.

Allison 4th Generation Controls displays fluid level diagnostic information two characters at a time.

- **Low Fluid Level**—“**o L**” is displayed (“**o L**” represents “Fluid (Oil) Level Check Mode”), followed by “**L o**” (“**L o**” represents “Low Oil Level”) and the number of quarts the transmission fluid is low.

Example: **o L L o 0 2**

Where “2” indicates that 2 additional quarts of fluid will bring the fluid level within the middle of the “**o K**” zone.

- **High Fluid Level**—“**o L**” is displayed (“**o L**” represents “Fluid (Oil) Level Check Mode”), followed by “**H I**” (“**H I**” represents “High Oil Level”) and the number of quarts the transmission is overfilled.

Example: **o L H I 0 1**

Where “1” indicates 1 quart of fluid above the full transmission level.

- **Invalid for Display** — “**o L**” is displayed (“**o L**” represents “Fluid (Oil) Level Check Mode”), followed by “—” (for WTEC III Controls) or “— —” (for Allison 4th Generation Controls) and a numerical display. The numerical display is a fault code and indicates conditions are not proper to receive the fluid level information, or that there is a system malfunction. The fault codes that may be encountered are shown in the Fluid Level Fault Codes tables:

Fluid Level Fault Codes (for WTEC III Controls)

Display	Cause of Code
o,L, —, 0, X	Settling time too short
o,L, —, 5, 0	Engine speed (rpm) too low
o,L, —, 5, 9	Engine speed (rpm) too high
o,L, —, 6, 5	Neutral must be selected
o,L, —, 7, 0	Sump fluid temperature too low
o,L, —, 7, 9	Sump fluid temperature too high
o,L, —, 8, 9	Output shaft rotation
o,L, —, 9, 5	Sensor failure*

* Report sensor failure display to a distributor or dealer in your area (check the telephone directory for an Allison Transmission distributor or dealer).

Fluid Level Fault Codes (for Allison 4th Generation Controls)

Display	Cause of Code
oL, - -, 0X	Settling time too short
oL, - -, 50	Engine speed (rpm) too low
oL, - -, 59	Engine speed (rpm) too high
oL, - -, 65	Neutral must be selected
oL, - -, 70	Sump fluid temperature too low
oL, - -, 79	Sump fluid temperature too high
oL, - -, 89	Output shaft rotation
oL, - -, 95	Sensor failure*

* Report sensor failure display to a distributor or dealer in your area (check the telephone directory for an Allison Transmission distributor or dealer).



CAUTION: A low or high fluid level can cause overheating and irregular shift patterns. Incorrect fluid level can damage the transmission.



NOTE: To exit the fluid level display mode, press any range button on the pushbutton shift selector, or press the display mode (diagnostic) button once on the lever shift selector.

MANUAL FLUID CHECK PROCEDURE

Refer to Figure 1 through Figure 4 for the location of the fill tube and dipstick.



WARNING: If you leave the vehicle and the engine is running, the vehicle can move unexpectedly and you or others could be injured. If you must leave the engine running, do not leave the vehicle until you have completed all of the following procedures:

1. Put the transmission in **N** (Neutral).
2. Be sure the engine is at low idle (500–800 rpm).
3. Apply the parking brakes and emergency brake and make sure they are properly engaged.
4. Chock the wheels and take any other steps necessary to keep the vehicle from moving.

Clean around the end of the fill tube before removing the dipstick. This will aid in preventing dirt or foreign matter from entering the hydraulic system, which can cause:

- Valves to stick.
- Undue wear of transmission parts.
- Clogged passages.

Check the fluid level using the procedures in **COLD CHECK** and **HOT CHECK**. Report an abnormal fluid level to service management.

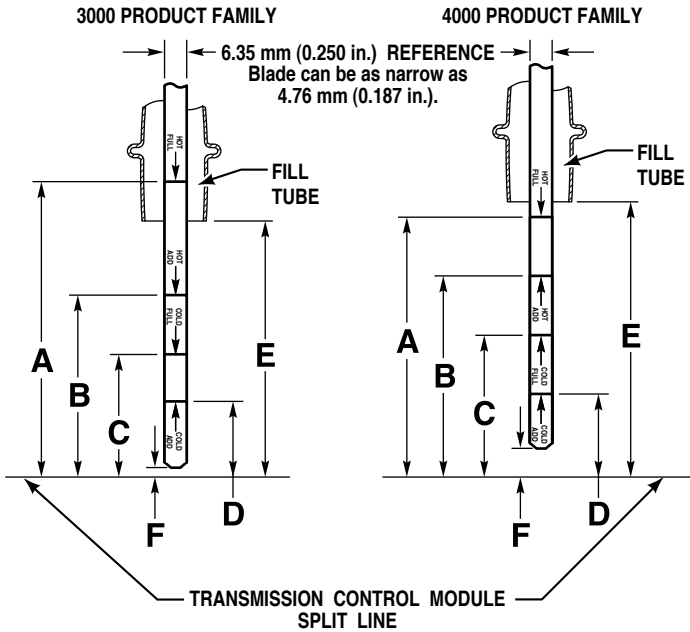

OIL SUMP	TRANSMISSION/SUMP DESCRIPTION	DIMENSION A	DIMENSION B	DIMENSION C	DIMENSION D	DIMENSION E	DIMENSION F**
2.00 in. and 4.00 in.****	4000 PRODUCT FAMILY	106.7 mm (4.20 in.)	76.2 mm (3.00 in.)	66.0 mm (2.60 in.)	*	132.6 mm (5.22 in.)	13.8 mm (0.54 in.)
2.00 in.***	3000 PRODUCT FAMILY	101.6 mm (4.00 in.)	73.7 mm (2.90 in.)	50.8 mm (2.00 in.)	*	86.6 mm (3.41 in.)	5.9 mm (0.23 in.)
4.00 in.***	3000 PRODUCT FAMILY	101.6 mm (4.00 in.)	63.5 mm (2.50 in.)	45.7 mm (1.80 in.)	*	86.6 mm (3.41 in.)	5.9 mm (0.23 in.)

NOTE: Calibrate level marking locations with respect to transmission control module split line and fill tube.
Scale none.

*Dimension determined by installation.

**Reference dimension only. Actual dimension to be determined by installation.

***Reference drawing AS66-60.

****Reference drawing AS67-60.

V07301.00.01

Figure 11. Standard Motorhome Series Transmission Dipstick Markings

COLD CHECK

The Cold Check determines if the transmission has enough fluid to be operated safely until a Hot Check can be made.



NOTE: The correct fluid level **can not be determined** unless the transmission is in a level position.



CAUTION: DO NOT start the engine until the presence of sufficient transmission fluid has been confirmed. Remove the transmission fluid dipstick and be sure the static fluid level is near the HOT FULL mark.



CAUTION: The fluid level rises as fluid temperature rises. DO NOT fill the transmission above the “COLD CHECK” band if the transmission fluid is below normal operating temperatures. During operation, an overfull transmission can become overheated, leading to transmission damage.

A cold check may be made after initial start-up and the presence of transmission fluid has been confirmed (the sump fluid temperature is then typically 16°–49°C (60°–120°F). To perform a COLD CHECK, do the following:

1. Start the engine and run it at idle (500–800 rpm) in **N** (Neutral) for about one minute.
2. Shift to **D** (Drive) and then to **R** (Reverse) to clear the hydraulic circuits of air.
3. Shift to **N** (Neutral) and leave engine at idle.
4. Move the vehicle to a level surface, put transmission in **N** (Neutral), and set the parking brake.
5. With the engine idling (500–800 rpm), shift to **D** (Drive) and then to **R** (Reverse) to clear air from the hydraulic circuits.
6. Shift to **N** (Neutral) and leave engine at idle.
7. Remove the dipstick and wipe it clean. Insert the dipstick into the fill tube, pushing down until it stops.
8. Remove the dipstick and observe the fluid level. If the fluid on the dipstick is within the COLD CHECK band, the level is satisfactory. If the fluid level **is not** within this band, add or drain fluid as necessary to bring the level within the COLD CHECK band.
9. Perform a Hot Check at the first opportunity after normal operating temperature (71°–93°C; 160°–200°F) is reached.



CAUTION: DO NOT operate the transmission for extended periods of time until a Hot Check has verified proper fluid level. Transmission damage can result from extended operation at improper fluid level conditions.



CAUTION: Obtain an accurate fluid level by imposing the following conditions:

- Engine is idling (500–800 rpm) in **N** (Neutral)
- Transmission fluid is at the normal operating temperature
- The vehicle is on a level surface

HOT CHECK

The transmission fluid **must be hot** to obtain an accurate check, because the fluid level rises as temperature increases.

To perform a HOT CHECK, do the following:

1. Be sure fluid has reached normal operating temperature (71°–93°C; 160°–200°F). If a transmission temperature gauge is not present, check fluid level when the engine water temperature gauge has stabilized and the transmission has been operated under load for at least one hour.
2. Park the vehicle on a level surface and shift to **N** (Neutral). Apply the parking brake and allow the engine to idle (500–800 rpm).
3. Remove the dipstick and wipe it clean. Insert the dipstick into the fill tube, pushing down until it stops.
4. Remove the dipstick and observe the fluid level. The safe operating level is anywhere within the HOT RUN band on the dipstick.
5. If the level is not within this band, add or drain fluid as necessary to bring the level within the HOT RUN band.
6. Be sure fluid level checks are consistent. Check level more than once and if readings are not consistent, check to be sure the transmission breather is clean and not clogged. If readings are still not consistent, contact your nearest Allison distributor or dealer.

RECOMMENDED AUTOMATIC TRANSMISSION FLUID AND VISCOSITY GRADE

- Hydraulic fluids used in the transmission are important influences on transmission performance, reliability, and durability. TranSynd™ and DEXRON®-III/VI fluids are recommended for on-highway applications. TranSynd™ and DEXRON®-III/VI fluids are recommended for all Motorhome Series applications.

- TranSynd™ is a full synthetic transmission fluid developed by Allison Transmission and Castrol Ltd. This fluid meets Allison specifications for Severe Duty and Extended Drain Intervals. TranSynd™ is fully qualified to the Allison TES 295 specifications and is available through Allison distributors and dealerships.
- To be sure a fluid is qualified for use in Allison transmissions check for the DEXRON®-III/VI license numbers on the container or consult the lubricant manufacturer. Consult your Allison Transmission dealer or distributor before using other fluid types.



CAUTION: Disregarding minimum fluid temperature limits can result in transmission malfunction or reduced transmission life.

- When choosing the optimum viscosity grade of fluid, duty cycle, preheat capabilities, and/or geographical location must be taken into consideration. The Transmission Fluid Operating Temperature Requirements table lists the minimum fluid temperatures at which the transmission may be safely operated without preheating. Preheat with auxiliary heating equipment or by running the equipment or vehicle with the transmission in neutral for a minimum of 20 minutes before attempting range operation.

Transmission Fluid Operating Temperature Requirements

SAE Viscosity Grade* or Fluid Type	Minimum Operating Temperature	
	Celsius	Fahrenheit
MIL-PRF-46167	-32	-25
SAE 0W-20 or TranSynd™	-30	-22
DEXRON®-III/VI	-25	-13
SAE 10W	-20	-4
SAE 15W-40	-15	5
SAE 30W	0	32
SAE 40W	10	50

* SAE "W" designation indicates winter weight based on cold temperature properties.

KEEPING FLUID CLEAN



CAUTION: Containers or fillers that have been used for antifreeze solution or engine coolant must NEVER be used for transmission fluid. Antifreeze and coolant solutions contain ethylene glycol which, if put into the transmission, can cause the clutch plates and some seals to fail.

It is absolutely necessary that transmission fluid be clean. The fluid **must be handled** in clean containers to prevent foreign material from entering the transmission.

FLUID AND INTERNAL FILTER CHANGE INTERVAL RECOMMENDATIONS



CAUTION: Transmission fluid and filter change frequency is determined by the severity of transmission service. To help avoid transmission damage, more frequent changes can be necessary than recommended in the general guidelines when operating conditions create high levels of contamination or overheating.

Allison requires all 3000 and 4000 Product Family transmissions to have the main filter (not the lube filter or fluid) changed after the first 5000 mile (8000 km) or 200 hours of operation, whichever comes first. Refer to the latest revision of Service Tips #1099 for convenient kit and fluid information. Refer to Mechanic’s Tips, latest version, for location of the main filter and the filter change procedure. Service Tips #1099 and Mechanic’s Tips are available online at www.allisontransmission.com.

Refer to the following Recommended Fluid/Filter Change tables for guidelines for fluid and filter change intervals.



NOTE: Change fluid/filters at or before recommended mileage, months, or hours have elapsed, whichever comes first. In some cases, operating hours may represent a more reliable measure of oil life; therefore, fluid change intervals should not be based on mileage alone.

Recommended Fluid/Filter Change For 3000 MH Transmissions

NOTE: Severe and General Vocations—Local conditions, severity of operation, or duty cycle may require more or less frequent fluid change intervals that differ from the published recommended fluid change intervals of Allison Transmission. Transmission protection and fluid change intervals can be optimized by using fluid analysis. Filters **must be changed** at or before recommended intervals. Change fluid/filter after recommended mileage, months, or hours have elapsed, whichever comes first.

SEVERE VOCATION*				GENERAL VOCATION**			
Fluid		Filters		Fluid		Filters	
		Main	Internal			Lube/ Auxiliary	Internal
Schedule 1 —Non-TranSynd™/Non-TES 295 Fluid							
12,000 Miles (20 000 km) 6 Months 500 Hours	12,000 Miles (20 000 km) 6 Months 500 Hours	Overhaul	12,000 Miles (20 000 km) 6 Months 500 Hours	25,000 Miles (40 000 km) 12 Months 1000 Hours	25,000 Miles (40 000 km) 12 Months 1000 Hours	Overhaul	25,000 Miles (40 000 km) 12 Months 1000 Hours
Schedule 2 ***—TranSynd™/TES 295 Fluid							
75,000 Miles (120 000 km) 36 Months 3000 Hours	75,000 Miles (120 000 km) 36 Months 3000 Hours	Overhaul	75,000 Miles (120 000 km) 36 Months 3000 Hours	150,000 Miles (240 000 km) 48 Months 4000 Hours	150,000 Miles (240 000 km) 48 Months 4000 Hours	Overhaul	75,000 Miles (120 000 km) 36 Months 3000 Hours

* Motorhome Series Transmissions with retarders or on/off-highway.

** Motorhome Series Transmissions without retarders and on-highway only.

*** Recommendations in Schedule 2 are based on the transmission containing 100 percent TranSynd™ fluid and Allison Transmission Gold Series filters.

Recommended Fluid/Filter Change For 4000 MH Transmissions

NOTE: Severe and General Vocations—Local conditions, severity of operation, or duty cycle may require more or less frequent fluid change intervals that differ from the published recommended fluid change intervals of Allison Transmission. Transmission protection and fluid change intervals can be optimized by using fluid analysis. Filters **must be changed** at or before recommended intervals. Change fluid/filter after recommended mileage, months, or hours have elapsed, whichever comes first.

SEVERE VOCATION*			GENERAL VOCATION**		
Fluid	Filters		Fluid	Filters	
	Main	Internal		Main	Internal
Schedule 1—Non-TranSynd™/Non-TES 295 Fluid					
12,000 Miles (20 000 km) 6 Months 500 Hours	12,000 Miles (20 000 km) 6 Months 500 Hours	Overhaul	25,000 Miles (40 000 km) 12 Months 1000 Hours	25,000 Miles (40 000 km) 12 Months 1000 Hours	25,000 Miles (40 000 km) 12 Months 1000 Hours
Schedule 2*** —TranSynd™/TES 295 Fluid					
4 Inch Control Module (3.5 Inch Approximately)—Requires Filter Kit P/N 29540494					
75,000 Miles (120 000 km) 36 Months 3000 Hours	75,000 Miles (120 000 km) 36 Months 3000 Hours	Overhaul	150,000 Miles (240 000 km) 48 Months 4000 Hours	75,000 Miles (120 000 km) 36 Months 3000 Hours	75,000 Miles (120 000 km) 36 Months 3000 Hours

* Motorhome Series with retarders or on/off-highway.

** Motorhome Series Transmissions without retarders and on-highway only.

*** Recommendations in Schedules 2 and 3 are based on the transmission containing 100 percent TranSynd™ fluid and Allison Transmission Gold Series filters.

Recommended Fluid/Filter Change For 4000 MH Transmissions (cont'd)

NOTE: Severe and General Vocations—Local conditions, severity of operation, or duty cycle may require more or less frequent fluid change intervals that differ from the published recommended fluid change intervals of Allison Transmission. Transmission protection and fluid change intervals can be optimized by using fluid analysis. Filters **must be changed** at or before recommended intervals. Change fluid/filter after recommended mileage, months, or hours have elapsed, whichever comes first.

SEVERE VOCATION*				GENERAL VOCATION**			
Fluid		Filters		Fluid		Filters	
		Main	Internal			Main	Internal
50,000 Miles (80 000 km) 24 Months 2000 Hours		Lube/ Auxiliary		50,000 Miles (80 000 km) 24 Months 2000 Hours		Lube/ Auxiliary	
		Overhaul	Overhaul			Main	Internal
2 Inch Control Module (1.75 Inch Approximately) —Requires Filter Kit P/N 29540493							
50,000 Miles (80 000 km) 24 Months 2000 Hours		50,000 Miles (80 000 km) 24 Months 2000 Hours		150,000 Miles (240 000 km) 48 Months 4000 Hours		50,000 Miles (80 000 km) 24 Months 2000 Hours	
Overhaul		Overhaul		Overhaul		Overhaul	

Schedule 3*** — TranSynd™/TES 295 Fluid

* Motorhome Series with retarders or on/off-highway.

** Motorhome Series Transmissions without retarders and on-highway only.

*** Recommendations in Schedules 2 and 3 are based on the transmission containing 100 percent TranSynd™ fluid and Allison Transmission Gold Series filters.



CAUTION: Transmission fluid and filters **must be changed** whenever there is evidence of dirt or a high temperature condition. A high temperature condition is indicated when the transmission fluid is discolored, has a strong odor, or has exceeded oil analysis limits.

Fluid Analysis

Transmission protection and fluid change intervals may be optimized by monitoring fluid oxidation according to the tests and limits shown in the Fluid Oxidation Measurement Limits table. Consult your local telephone directory for fluid analysis firms. To be sure of consistent and accurate fluid analysis, use only one fluid analysis firm. Refer to Technician's Guide for Automatic Transmission Fluid, GN2055EN, for additional information.

Fluid Oxidation Measurement Limits

Test	Limit
Viscosity	±25 percent change from new fluid
Total Acid Number (TAN)	+3.0* change from new fluid
Solids	2 percent by volume
* mg of potassium hydroxide (KOH) to neutralize a gram of fluid.	

TRANSMISSION FLUID CONTAMINATION

Fluid Examination. At each fluid change, examine the drained fluid for evidence of dirt or water. A normal amount of condensation will appear in the fluid during operation.

Water. Obvious water contamination of the transmission fluid or transmission fluid in the cooler (heat exchanger) water indicates a leak between the water and fluid areas of the cooler. Inspect and pressure test the cooler to confirm the leak. Replace leaking coolers.



NOTE: Cooler water can also be contaminated by engine oil; be sure to locate the correct source of cooler water contamination.

Engine Coolant. Engine coolant in the transmission hydraulic system requires immediate action to prevent malfunction and possible serious damage. An authorized Allison service outlet must completely disassemble, inspect, and clean the transmission. All traces of the coolant, and varnish deposits resulting from engine coolant contamination must be removed. Friction clutch plates contaminated with engine coolant (ethylene glycol) must be replaced.

Metal. Metal particles in the fluid (except for the minute particles normally trapped in the oil filter) indicate internal transmission damage. If these particles are found in the sump, the transmission must be disassembled and closely inspected to find their source. Metal contamination requires complete transmission disassembly. Clean all internal and external hydraulic circuits, cooler, and all other areas where the particles could lodge.



CAUTION: After flushing the cooler, be sure to check cooler circuit restriction. If circuit pressure drop is above specification, the cooler has excessive trapped particles and must be replaced. Excessive pressure drop impedes transmission cooling which can cause overheating and transmission damage.

TRANSMISSION FLUID AND FILTER CHANGE PROCEDURE

Drain Fluid.



NOTE: Do not drain the transmission fluid if only filters are being replaced.



WARNING: Avoid contact with the hot fluid or the sump when draining transmission fluid. Direct contact with the hot fluid or the hot sump may result in bodily injury.

1. Drain the fluid when the transmission is at operating temperature of 71–93°C (160–200°F). Hot fluid flows quicker and drains more completely.
2. Remove the drain plug from the control module and allow the fluid to drain into a suitable container.
3. Examine the fluid as described in the TRANSMISSION FLUID CONTAMINATION paragraph.

Replace Filters (Refer to Figure 12).

1. Remove twelve bolts (1), two filter covers (2), two gaskets (3), two O-rings (4), two O-rings (5), and two filters (6) from the bottom of the control module.
2. When reinstalling parts, lubricate and install new O-rings (4) and (5) on each cover (2). Lubricate O-ring inside filter (6) and push filter onto each cover (2). Install new gasket (3) on each cover (2) and align holes in gasket with holes in cover.

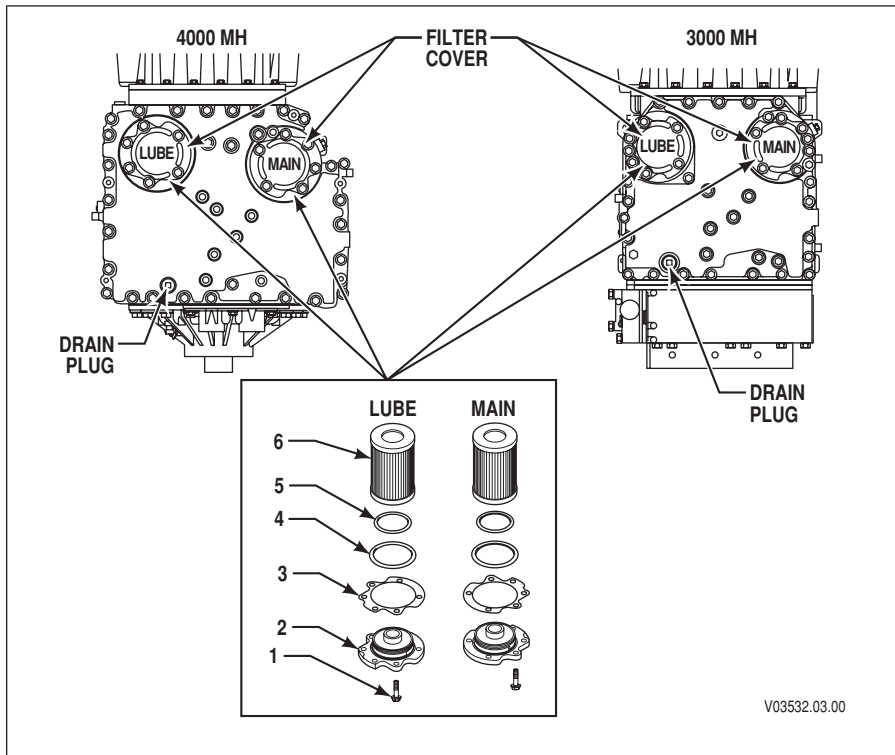

Figure 12. Location of Filters for Service



CAUTION: Do not use the bolts to draw the filter covers to the control module. Do not use an impact wrench to tighten the bolts. Using an impact wrench to tighten the bolts can strip threads and cause expensive parts replacement. Use a torque wrench to tighten the bolts.

3. Install filter and cover assemblies into the filter compartment. Align each filter/cover assembly with the holes in the channel plate/sump. Push the cover assemblies in by hand to seat the seals.
4. Install six bolts into each cover and tighten to 51–61 N•m (38–45 lb ft).
5. Replace the drain plug O-ring. Install the plug and tighten to 25–32 N•m (18–24 lb ft).

Refill Transmission. The amount of refill fluid is less than the amount used for the initial fill. Fluid remains in the external circuits and transmission cavities after draining the transmission. After refill, check the fluid level. Refer to **FLUID LEVEL CHECK USING PUSHBUTTON OR LEVER SHIFT SELECTOR** paragraph.



NOTE: Quantities listed are approximations and do not include external lines and cooler hose.

Transmission Fluid Capacity

Transmission	Sump	Initial Fill		Refill	
		Liters	Quarts	Liters	Quarts
3000 MH	4 inch	27	29	18	19
	2 inch	25	26	16	17
4000 MH*	4 inch	45	48	37	39
	2 inch	38	40	30	31
* Add 2.8 Liters (3 Quarts) for transmissions with PTO.					

MOTORHOME SERIES

DIAGNOSTICS

DIAGNOSTIC CODES

Continued illumination of the **CHECK TRANS** light during vehicle operation (not start-up) indicates the TCM/ECU has signaled a diagnostic code. Poor performance may activate a code without illuminating the **CHECK TRANS** light. Up to five diagnostic codes can be recorded. Diagnostic codes can be read and cleared by two methods: by using the shift selectors shown below or using the Allison DOC™ Diagnostic Tool for the PC or PDA. Use of the Allison DOC™ Diagnostic Tool for the PC or PDA is described in the instruction manual furnished with each tool. Basic information on code reading, code clearing and troubleshooting is covered in this DIAGNOSTICS section. For additional information, refer to TS3989EN Troubleshooting Manual for Allison 4th Generation Controls. More detailed information is available in the Troubleshooting Manual. Refer to the SERVICE LITERATURE section for the appropriate publication number.

Diagnostic codes are numerical indications relating to a malfunction in transmission operation. In WTEC III Controls, each code consists of a two-digit main code and a two-digit subcode. In Allison 4th Generation Controls, each code consists of five characters. The first character is a letter followed by a four digit numeric string. These codes are logged in a list in the TCM/ECU memory with the most severe or otherwise most recent code listed first. A maximum of five codes (numbered d1–d5) may be listed in memory at one time. As codes are added, the oldest non-active code is dropped from the list. If all codes are active, the code with the lowest priority that is not included on the severity list is dropped from the list. Access to the diagnostic codes and code information is through the pushbutton and lever shift selectors or the diagnostic data reader.

The TCM/ECU separately stores the active and historical (non-active) codes. An active code is any code that is current in the TCM/ECU decision-making process. Historical codes are codes that are retained in the TCM/ECU's memory and will not necessarily affect the TCM/ECU decision-making process. Historical codes are useful in determining if a problem is isolated, is intermittent, or results from a previous malfunction.

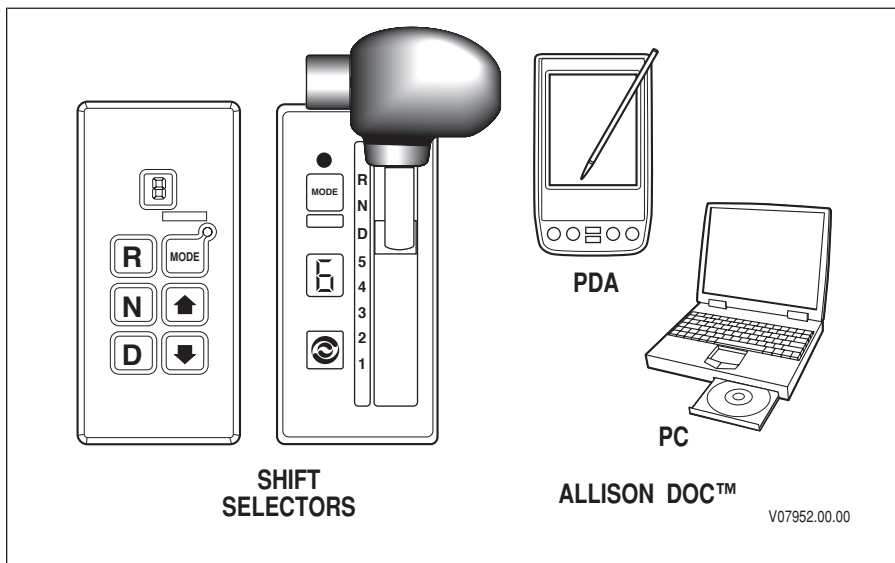

Figure 13. Shift Selector/Allison DOC™ Diagnostic Tool

DIAGNOSTIC CODES

Diagnostic Codes Overview. Diagnostic codes are numerical indications relating to a malfunction in transmission operation. These codes are logged in a list in the TCM/ECU memory with the most severe or most recent code listed first. A maximum of five codes (numbered d1–d5) may be listed in memory at one time. As codes are added, the oldest non-active code is dropped from the list. If all codes are active, the code with the lowest priority that is not included on the severity list is dropped from the list.

Diagnostic codes and code information may be accessed through the pushbutton and lever shift selectors or using an Allison DOC™ diagnostic tool.

The TCM/ECU separately stores the active and historical (non-active) codes. An active code is any code that is current in the TCM/ECU decision-making process.

Historical codes are codes that are retained in the TCM/ECU's memory and will not necessarily affect the TCM/ECU decision-making process. Historical codes are useful in determining if a problem:

- Is isolated.
- Is intermittent.
- Results from a previous malfunction.

The TCM/ECU may automatically delete a code from memory if it has not recurred.

If the MODE INDICATOR (LED) is illuminated, the displayed code is active. If the mode indicator (refer to Figure 7 and Figure 8) is not illuminated, the displayed code is not active. An illuminated mode indicator during normal operation signifies secondary mode operation.

Diagnostic Codes—WTEC III Controls. When the diagnostic mode is entered, the first code (position d1) is displayed as follows:

Example—Code 1312:

Displayed as: **d, 1, 1, 3, 1, 2** (each item appears for about one second)

- d1 (code position)—Code position indicates that this is the first diagnostic code listed in the ECU memory.
- 13 (main code)—Main codes (2 digits displayed one-at-a-time) are listed first and provide the general condition or area of a fault detected by the ECU.
- 12 (subcode)—Subcode (2 digits displayed one-at-a-time) are listed second and provide specific areas or conditions within the main code that cause the fault. This subcode indicates the problem is caused by low voltage.

Diagnostic Codes—Allison 4th Generation Controls. When the diagnostic mode is entered, the first code (position d1) is displayed as follows:

Example—Code P0722:

Displayed as: **d1, P, 07, 22**

The code list position is the first item displayed, followed by the DTC. Each item is displayed for about one second. The display cycles continuously until the next code list position is accessed by pressing the **MODE** button. The following example shows how DTC P0722 is displayed on the pushbutton and lever shift selectors.

SELECT	MONITOR
d	1
	P
0	7
2	2

- d1 (code list position)—The position which a code occupies in the code list. Positions are displayed as “d1” through “d5” (Code List Position 1 through Code List Position 5).
- P0722 (DTC)—The diagnostic trouble code number referring to the general condition or area of fault detected by the TCM.

DIAGNOSTIC CODE DISPLAY PROCEDURE

Diagnostic codes can be read and cleared by two methods:

- Using an Allison DOC™ diagnostic tool. For specific instructions on how to use an Allison DOC™ diagnostic tool, refer to the User Guide.
- Using the pushbutton or lever shift selector.

Pushbutton Shift Selector.

To begin the Diagnostic Process:

1. Bring the vehicle to a stop at a safe location.
2. Apply the parking brake.

To Display Stored Codes:

1. Simultaneously press the ↑ (Up) and ↓ (Down) arrow buttons once to access the Oil Level Display Mode—press the buttons a second time to access the Diagnostic Display Mode.
2. Observe the digital display for codes.
 - Diagnostic codes will appear one digit at a time on WTEC III pushbutton or lever shift selectors.
 - Diagnostic codes will appear two characters at a time on Allison 4th Generation Controls pushbutton or lever shift selectors.
3. Press the **MODE** button to see the next code—repeat for subsequent codes.



NOTE: Be sure to record all codes displayed before they are cleared. This is essential for troubleshooting.

To Clear Active Indicators and Inactive Codes then Resume Vehicle Operation:

1. Clear active indicators and inactive codes.
 - WTEC III Controls—To clear active indicators such as the **CHECK TRANS** light, press and hold the **MODE** button for approximately three seconds until the MODE INDICATOR (LED) flashes. Release the **MODE** button and active indicators will not be illuminated. To clear inactive codes, press and hold the **MODE** button for 10 seconds. Some codes are self-clearing and others require ignition cycles to clear.
 - Allison 4th Generation Electric Controls—Press and hold the **MODE** button for 10 seconds to clear both active indicators and inactive codes.
2. Begin operating as normal—have the transmission checked at the earliest opportunity by an Allison Transmission distributor or dealer.

Lever Shift Selector.

To Begin the Diagnostic Process:

1. Bring the vehicle to a stop at a safe location.
2. Apply the parking brake.

To Display Stored Codes:

1. Press the **DISPLAY MODE/DIAGNOSTIC** button once to access the diagnostic display mode—press the button twice if a transmission oil level sensor is installed.
2. Observe the digital display for codes.
 - Diagnostic codes will appear one digit at a time on WTEC III pushbutton or lever shift selectors.
 - Diagnostic codes will appear two characters at a time on Allison 4th Generation Controls pushbutton or lever shift selectors.
3. Press the **MODE** button to see the next code—repeat for subsequent codes.



NOTE: Be sure to record all codes displayed before they are cleared. This is essential for troubleshooting.

To Clear Active Indicators and Inactive Codes then Resume Vehicle Operation:

1. Clear active indicators and inactive codes.
 - WTEC III Controls—To clear active indicators such as the **CHECK TRANS** light, press and hold the **MODE** button for approximately three seconds until the **MODE INDICATOR (LED)** flashes. Release the **MODE** button and active indicators will not be illuminated. To clear inactive codes, press and hold the **MODE** button for 10 seconds. Some codes are self-clearing and others require ignition cycles to clear.
 - Allison 4th Generation Electric Controls—Press and hold the **MODE** button for 10 seconds to clear both active indicators and inactive codes.
2. Begin operating as normal—have the transmission checked at the earliest opportunity by an Allison Transmission distributor or dealer.



NOTE: If the condition that caused the code is still present, the code will again become active.

DIAGNOSTIC CODE LISTINGS AND PROCEDURES (WTEC III CONTROLS)

The following table presents information about the diagnostic codes which may occur during the operation of the transmission. For additional information, refer to TS2973EN Troubleshooting Manual for WTEC III Controls.

Code Listings And Procedures (WTEC III Controls)

CODES		QUICK CHECKS
MAIN CODE	SUB CODE	
13	12	Check: a. Battery direct ground and power connections are tight and clean. b. Vehicle batteries are charged. c. Vehicle charging system is not over- or under-charging. d. VIM fuse is good. e. VIM connections are tight, clean, and undamaged. f. Vehicle manufacturer supplied wiring is correct. g. ECU connectors are tight, clean, and undamaged.
ECU Input Voltage Low		
13	13	
ECU Input Voltage Medium Low		
13	23	
ECU Input Voltage High		
14	12, 23	
Oil Level Sensor		
21	12, 23	Check: a. TPS connector is properly connected. b. End of TPS cable is pulled out properly. c. Engine fuel lever is in idle position. d. Engine fuel lever provides proper amount of stroke on TPS cable. e. Wiring harness to TPS has no opens, shorts-between-wires, or shorts-to-ground. f. TPS for proper operation and resistance readings.
Throttle Position Sensor		

Code Listings And Procedures (WTEC III Controls) (cont'd)

CODES		QUICK CHECKS
MAIN CODE	SUB CODE	
22	14, 15, 16	Check: a. Speed sensors and connectors are tight, clean, and undamaged. b. Wiring harness to sensors has no opens, shorts-between-wires, or shorts-to-ground.
Speed Sensors		
23	12, 13, 14, 15, 16	Check: a. ECU connectors are tight, clean, and undamaged. b. Shift selector connector is tight, clean, and undamaged. c. Wiring harness has no opens, shorts-between-wires, or shorts-to-ground. d. Shift selector(s) for proper operation.
Shift Selectors		
24	12	Check: a. Air temperature is below -32°C (-25°F) <ul style="list-style-type: none"> • If yes, this is a correct response for temperature. • If no, check that main transmission connector is tight, clean, and undamaged. b. ECU connectors are tight, clean, and undamaged.
Sump Fluid Temperature Cold		
24	23	Verify the overheat situation. Check: a. Correct dipstick is installed. b. Fluid level is correct. Refer to CARE AND MAINTENANCE section. <ul style="list-style-type: none"> • If fluid level is incorrect—correct fluid level. • If fluid level is correct—check for cause of overheating. c. Check if ECU and transmission connectors are tight, clean, and undamaged.
Sump Fluid Temperature Hot		
25	00, 11, 22, 33, 44, 55, 66, 77	Check: a. Speed sensor connector is tight, clean, and undamaged. b. ECU connectors are tight, clean, and undamaged. c. Fluid level is correct. Refer to CARE AND MAINTENANCE section. d. Wiring harness to sensor has no opens, shorts-between-wires, or shorts-to-ground.
Output Speed Sensor		

Code Listings And Procedures (WTEC III Controls) (cont'd)

CODES		QUICK CHECKS
MAIN CODE	SUB CODE	
26	00, 11	Check: a. TPS for proper operation, related harness for opens and shorts. b. Serial connection to engine is tight, clean, and undamaged. c. SCI wiring harness has no opens or shorts.
Throttle/Engine Coolant Source Not Detected		
32	00, 33, 55, 77	Check: a. Correct dipstick is installed. b. Fluid level is correct. Refer to CARE AND MAINTENANCE section. c. Main transmission connector is tight, clean, and undamaged. d. ECU connectors are tight, clean, and undamaged. e. Wiring harness has no opens, shorts-between-wires, or shorts-to-ground.
C3 Pressure Switch Open		
33	12, 23	Check: a. Main transmission connector is tight, clean, and undamaged. b. ECU connectors are tight, clean, and undamaged. c. Wiring harness has no opens, shorts-between-wires, or shorts-to-ground.
Sump Oil Temperature Sensor Failure		
34	12, 13, 14, 15, 16, 17	a. Recalibrate ECU, if possible. b. Replace ECU if not possible to recalibrate.
EEPROM		
35	00, 16	Check: a. ECU connectors are tight, clean, and undamaged. b. VIM connectors are tight, clean, and undamaged. c. Vehicle manufacturer supplied wiring has correct power and ground connections. d. Power connections are battery direct. e. Ground connections are battery direct. f. Ignition switch connections are correct.
Power Interruption Real Time Write Interruption		

Code Listings And Procedures (WTEC III Controls) (cont'd)

CODES		QUICK CHECKS
MAIN CODE	SUB CODE	
36	00, 01, 02	a. If able, recalibrate ECU; if not, replace ECU. b. Check that ECU is compatible with TransID level (36 01). c. Troubleshoot TransID wire and circuit for short-to-battery (36 02).
Hardware/Software Not Compatible		
42	12, 13, 14, 15, 16, 21, 22, 23, 24, 26	Check: a. Main transmission connector is tight, clean, and undamaged. b. ECU connectors are tight, clean, and undamaged. c. Wiring harness is not pulled too tight, and there is no damage, chafing, or screws through harness. d. Wiring harness has no opens, shorts-between-wires, or shorts-to-ground. e. Unauthorized repairs have not been made. f. Change harness (optional).
Short-to-Battery in Solenoid Circuit		
44	12, 13, 14, 15, 16, 21, 22, 23, 24, 26	Check: a. Main transmission connector is tight, clean, and undamaged. b. ECU connectors are tight, clean, and undamaged. c. Wiring harness has no opens, shorts-between-wires, or shorts-to-ground.
Solenoid Circuit Short-to-Ground		
45	12, 13, 14, 15, 16, 21, 22, 23, 24, 26	Check: a. Main transmission connector is tight, clean, and undamaged. b. ECU connectors are tight, clean, and undamaged. c. Wiring harness has no opens or shorts.
Solenoid Circuit Open		
46	21, 26, 27	Check: a. Main transmission connector is tight, clean, and undamaged. b. ECU connectors are tight, clean, and undamaged. c. Wiring harness has no opens, shorts-between-wires, or shorts-to-ground. d. Replace ECU.
Solenoid Overcurrent		

Code Listings And Procedures (WTEC III Controls) (cont'd)

CODES		QUICK CHECKS
MAIN CODE	SUB CODE	
51	01, 10, 12, 21, 23, 24, 35, 42, 43, 45, 46, 53, 64, 65, XY*	Check: <ol style="list-style-type: none"> a. Output and turbine speed sensor connectors are tight, clean, and undamaged. b. Speed sensor wiring harness has no opens, shorts-between-wires, or shorts-to-ground. c. Correct dipstick is installed. d. Fluid level is correct. Refer to CARE AND MAINTENANCE section.
Offgoing Ratio Test (During Shift)		
52	01, 08, 32, 34, 54, 56, 71, 72, 78, 79, 99, XY*	Check: <ol style="list-style-type: none"> a. Output and turbine speed sensor connectors are tight, clean, and undamaged. b. Speed sensor wiring harness has no opens, shorts-between-wires, or shorts-to-ground. c. Main wiring harness to transmission has no shorts-between-wires or shorts-to-ground. d. Correct dipstick is installed. e. Fluid level is correct. Refer to CARE AND MAINTENANCE section.
Offgoing C3 Pressure Switch Test (During Shift)		
53	08, 09, 18, 19, 28, 29, 38, 39, 48, 49, 58, 59, 68, 69, 78, 99, XY*	Check: <ol style="list-style-type: none"> a. Turbine and engine speed sensor connectors are tight, clean, and undamaged. b. Speed sensor wiring harness has no opens, shorts-between-wires, or shorts-to-ground. c. Correct dipstick is installed. d. Fluid level is correct. Refer to CARE AND MAINTENANCE section.
Offgoing Speed Test (During Shift)		
*Additional codes could be logged for other shifts where X indicates range shifted from and Y indicates range shifted to.		

Code Listings And Procedures (WTEC III Controls) (cont'd)

CODES		QUICK CHECKS
MAIN CODE	SUB CODE	
54	01, 07, 10, 12, 17, 21, 23, 24, 27, 32, 34, 35, 42, 43, 45, 46, 53, 54, 56, 64, 65, 70, 71, 72, 80, 81, 82, 83, 85, 86, 87, 92, 93, 95, 96, XY*	Check: a. Turbine and output speed sensor connectors are tight, clean, and undamaged. b. Speed sensor wiring harness has no opens, shorts-between-wires, or shorts-to-ground. c. Correct dipstick is installed. d. Fluid level is correct. Refer to CARE AND MAINTENANCE section. e. EEPROM calibration is correct for the transmission.
Oncoming Ratio Test (After Shift)		
55	07, 17, 27, 87, 97, XY*	Check: a. Correct dipstick is installed. b. Fluid level is correct. Refer to CARE AND MAINTENANCE section. c. Output and turbine speed sensor connectors are tight, clean, and undamaged. d. Speed sensor wiring harness has no opens, shorts-between-wires, or shorts-to-ground. e. Transmission connector is tight, clean, and undamaged. f. ECU connectors are tight, clean, and undamaged. g. C3 pressure switch wiring has no opens, shorts-between-wires, or shorts-to-ground.
Oncoming C3 Pressure Switch Test (After Shift)		
*Additional codes could be logged for other shifts where X indicates range shifted from and Y indicates range shifted to.		

Code Listings And Procedures (WTEC III Controls) (cont'd)

CODES		QUICK CHECKS
MAIN CODE	SUB CODE	
56	00, 11, 22, 33, 44, 55, 66, 77	Check: a. Turbine and output speed sensor connectors are tight, clean, and undamaged. b. Speed sensor wiring harness has no opens, shorts-between-wires, or shorts-to-ground. c. Transmission connector is tight, clean, and undamaged. d. ECU connectors are tight, clean, and undamaged. e. Correct dipstick is installed. f. Fluid level is correct. Refer to CARE AND MAINTENANCE section.
Range Verification Ratio Test		
57	11, 22, 44, 66, 88, 99	Check: a. Correct dipstick is installed. b. Fluid level is correct. Refer to CARE AND MAINTENANCE section. c. Output and turbine speed sensor connectors are tight, clean, and undamaged. d. Speed sensor wiring harness has no opens, shorts-between-wires, or shorts-to-ground. e. Transmission connector is tight, clean, and undamaged. f. ECU connectors are tight, clean, and undamaged. g. C3 pressure switch wiring has no opens, shorts-between-wires, or shorts-to-ground.
Range Verification C3 Pressure Switch Test		
61	00	Check: a. Fluid level is correct. Refer to CARE AND MAINTENANCE section. b. Retarder apply system is not allowing retarder and throttle to be applied at the same time. c. Fluid cooler is adequately sized for load.
Retarder Over Temperature		

Code Listings And Procedures (WTEC III Controls) (cont'd)

CODES		QUICK CHECKS
MAIN CODE	SUB CODE	
62	12, 23, 32, 33	Check: a. Retarder temperature measured with diagnostic tool is consistent with code; or determine if code is active using shift selector. b. Sensor connector is tight, clean and undamaged. c. ECU connectors are tight, clean, and undamaged. d. Temperature sensor circuit has no opens, shorts-between-wires, or shorts-to-ground. e. Serial connection to engine computer is tight, clean, and undamaged. f. SCI wiring harness has no opens or shorts.
Retarder Temperature Sensor, Engine Coolant Sensor		
63	00, 26, 40, 41, 47	Check input wiring, switches, and connectors to determine why input states are different.
Input Function Fault		
64	12, 23	Use diagnostic tool to read retarder counts and identify problem wires. Check wiring for short-to-battery, ground wire open, or short-to-ground.
Retarder Modulation Request Device Fault		
66	00, 11, 22	Check: a. b. c. a. Serial connection to engine computer is tight, clean, and undamaged. b. SCI wiring harness has no opens, shorts, or shorts-to-ground. c. If diagnostic tool is not available, also be sure that transmission ECU connections are tight, clean, and undamaged. d. Problem with CAN link or engine controls.
Serial Communications Interface Fault		
69	27, 28, 29, 33, 34, 35, 36, 39, 41, 42, 43	a. Clear diagnostic code and retry vehicle start. b. If code recurs, reprogram or replace ECU.
ECU Malfunction		
70	12, 13, 14	Reset ECU
Software Problem		

DIAGNOSTIC CODE LISTINGS AND PROCEDURES (ALLISON 4th GENERATION CONTROLS)

The following table presents information about the diagnostic codes which may occur during the operation of the transmission. For additional information, refer to TS3989EN Troubleshooting Manual for Allison 4th Generation Controls.

Code Listings And Procedures (Allison 4th Generation Controls)

CODES	QUICK CHECKS
C1312, C1313 Retarder Request Sensor Fault	Use an Allison DOC™ diagnostic tool to read Retarder Request Percentage. Check wiring for short-to-battery, ground wire open, or short-to-ground.
P0122, P0123 Pedal Position Sensor Fault	<ol style="list-style-type: none"> 1. Check: <ol style="list-style-type: none"> a. TPS connector is properly connected. b. End of TPS cable is pulled out properly. c. Engine fuel lever is in idle position. d. Engine fuel lever provides proper amount of stroke on TPS cable. e. Wiring harness to TPS has no opens, shorts-between-wires, or shorts-to-ground. f. TPS for proper operation and resistance readings.
P0218 Transmission Over Temperature	<ol style="list-style-type: none"> 1. Verify the overheat situation and check: <ol style="list-style-type: none"> a. Correct dipstick is installed. b. Proper fluid level. Refer to CARE AND MAINTENANCE section. <ol style="list-style-type: none"> i. If fluid level is incorrect—correct the fluid level. ii. If fluid level is correct—check for the cause of overheating. 2. Check that the TCM and transmission connectors are tight, clean, and undamaged.
P0602 TCM Not Programmed	<ol style="list-style-type: none"> 1. Recalibrate the TCM. If unable to recalibrate, replace the TCM.
P0610 TCM Vehicle Options Error	<ol style="list-style-type: none"> 1. Update TCM calibration to match transmission configuration.

**Code Listings And Procedures
(Allison 4th Generation Controls) (cont'd)**

<p>P0613 TCM Processor</p>	<p>1. Contact Allison Transmission Technical Assistance Center at: 1-800-252-5283.</p>
<p>P0614 Torque Control Data Mismatch— TCM/ECM</p>	<p>1. Check:</p> <ul style="list-style-type: none"> a. Data link communication connectors at engine and transmission controllers are tight, clean, and undamaged. b. Data link communications wiring harness has no opens, shorts, or shorts-to-ground. <ul style="list-style-type: none"> — The resistance between J1939 CAN high and CAN low wires should be 60 Ohms. c. No unauthorized engine power updates were made. <p>2. Update engine software to be compatible with transmission torque requirements:</p> <ul style="list-style-type: none"> a. Add necessary engine torque control functions, or b. Reduce engine power and torque ratings.
<p>P0634 TCM Internal temperature too High</p>	<p>1. Check:</p> <ul style="list-style-type: none"> a. High temperature components such as exhaust lines in the vicinity of the TCM. <p>2. Shield or relocate TCM, if appropriate.</p>
<p>P063E Auto Configuration Throttle Input Not Present</p>	<p>1. Check:</p> <ul style="list-style-type: none"> a. Data link communication connectors at engine and transmission controllers are tight, clean, and undamaged. b. Data link communications wiring harness has no opens, shorts, or shorts-to-ground. <ul style="list-style-type: none"> — The resistance between J1939 CAN high and CAN low wires should be 60 Ohms c. TPS (if installed) for proper operation, related harness for opens and shorts.

Code Listings And Procedures
(Allison 4th Generation Controls) (cont'd)

<p>P063F Auto Configuration Engine Coolant Not Present</p>	<p>1. Check:</p> <ul style="list-style-type: none"> a. Data link communication connectors at engine and transmission controllers are tight, clean, and undamaged. b. Data link communications wiring harness has no opens, shorts, or shorts-to-ground. <ul style="list-style-type: none"> — The resistance between J1939 CAN high and CAN low wires should be 60 Ohms. c. Engine coolant temp sensor harness for opens and shorts.
<p>P0658, P0659, P2670, P2671, P2685, P2686 Actuator Supply Voltage Fault</p>	<p>1. Check:</p> <ul style="list-style-type: none"> a. Main transmission connector is tight, clean, and undamaged. b. TCM connector is tight, clean, and undamaged. c. Wiring harness has no opens, shorts-between-wires, or shorts-to-ground.
<p>P0701 Transmission Control System Performance</p>	<p>1. Let the vehicle idle with parking brake applied, wheels chocked, and vehicle level. Check:</p> <ul style="list-style-type: none"> a. Correct dipstick installed. b. Correct fluid level. <p>2. Check:</p> <ul style="list-style-type: none"> a. Main transmission connector is tight, clean, and undamaged. b. TCM connector is tight, clean, and undamaged. c. Wiring harness has no opens, shorts-between-wires, or shorts-to-ground.
<p>P0702 Transmission Control System Electrical</p>	<p>1. Check:</p> <ul style="list-style-type: none"> a. Main transmission connector is tight, clean, and undamaged. b. TCM connector is tight, clean, and undamaged. c. Wiring harness has no opens, shorts-between-wires, or shorts-to-ground.

Code Listings And Procedures
(Allison 4th Generation Controls) (cont'd)

<p>P0703 Brake Switch Circuit</p>	<p>1. Check:</p> <ul style="list-style-type: none"> a. Brake pressure switch, wiring, and connectors to determine why brake input is not being sent to the TCM.
<p>P0708 Transmission Range Sensor Circuit</p>	<p>1. Check:</p> <ul style="list-style-type: none"> a. TCM connector is tight, clean, and undamaged. b. Strip-type shift selector connector is tight, clean, and undamaged. c. Wiring harness has no opens, shorts-between-wires, or shorts-to-ground. <p>2. Strip-type shift selector for proper operation.</p>
<p>P070C, P070D Transmission Fluid Level Sensor Fault</p>	<p>1. Check:</p> <ul style="list-style-type: none"> a. Is the transmission equipped with an oil level sensor? b. Engine speed sensor, output speed sensor, temperature sensor, and oil level sensor working correctly. c. Wiring harness has no opens, shorts-between-wires, or shorts-to-ground.
<p>P0711, P0712, P0713 Transmission Fluid Temperature Circuit Fault</p>	<p>1. Check:</p> <ul style="list-style-type: none"> a. Correct fluid level. b. Main transmission connector is tight, clean, and undamaged. c. TCM connector is tight, clean, and undamaged. d. Wiring harness has no opens, shorts-between-wires, or shorts-to-ground.
<p>P0716, P0717, P0721, P0722, P0726, P0727 Speed Sensor Circuit Fault</p>	<p>1. Check:</p> <ul style="list-style-type: none"> a. Speed sensors and connectors are tight, clean, and undamaged. b. Wiring harness has no opens, shorts-between-wires, or shorts-to-ground.
<p>P0719 Brake Switch ABS Input Circuit Fault</p>	<p>1. Check input wiring, switches, and connectors to determine why ABS input is not being sent to the TCM.</p>

Code Listings And Procedures
(Allison 4th Generation Controls) (cont'd)

<p>P071A RELS Input Fault</p>	<ol style="list-style-type: none"> 1. Check brake pressure switch, wiring, and connectors to determine why RELS input is not being sent to the TCM.
<p>P071D General Purpose Input Fault</p>	<ol style="list-style-type: none"> 1. Check input wiring, switches, and connectors to determine why input states are different.
<p>P0729, P0731, P0732, P0733, P0734, P0735, P0736 Incorrect Gear Ratio</p>	<ol style="list-style-type: none"> 1. Check: <ol style="list-style-type: none"> a. Turbine and output speed sensor connectors are tight, clean, and undamaged. b. Speed sensor wiring harness has no opens, shorts-between-wires, or shorts-to-ground. c. Wiring harness has no opens, shorts-between-wires, or shorts-to-ground. 2. Let vehicle idle with parking brake applied, wheels chocked, and vehicle level. Check: <ol style="list-style-type: none"> a. Correct dipstick is installed. b. Fluid level is correct. 3. TCM calibration is correct for transmission model.
<p>P0741 Torque Converter Clutch System Stuck OFF</p>	<ol style="list-style-type: none"> 1. Check: <ol style="list-style-type: none"> a. Engine and turbine speed sensor connectors are tight, clean, and undamaged. b. Speed sensor wiring harness has no opens, shorts-between-wires, or shorts-to-ground. c. Wiring harness has no opens, shorts-between-wires, or shorts-to-ground. 2. Let vehicle idle with parking brake applied, wheels chocked, and vehicle level. Check: <ol style="list-style-type: none"> a. Correct dipstick is installed. b. Fluid level is correct.

Code Listings And Procedures
(Allison 4th Generation Controls) (cont'd)

<p>P0776, P0796, P2714, P2723 Pressure Control Solenoid Controlled Clutch Stuck OFF</p>	<ol style="list-style-type: none"> 1. Check: <ol style="list-style-type: none"> a. Turbine and output speed sensor connectors are tight, clean, and undamaged. b. Speed sensor wiring harness has no opens, shorts-between-wires, or shorts-to-ground. 2. Let vehicle idle with parking brake applied, wheels chocked, and vehicle level. Check: <ol style="list-style-type: none"> a. Correct dipstick is installed. b. Fluid level is correct.
<p>P0777, P0797, P2715, P2724 Pressure Control Solenoid Controlled Clutch Stuck ON</p>	<ol style="list-style-type: none"> 1. Check: <ol style="list-style-type: none"> a. Turbine and output speed sensor connectors are tight, clean, and undamaged. b. Speed sensor wiring harness has no opens, shorts-between-wires, or shorts-to-ground. 2. Let vehicle idle with parking brake applied, wheels chocked, and vehicle level. Check: <ol style="list-style-type: none"> a. Correct dipstick is installed. b. Fluid level is correct.
<p>P0842, P0843 Transmission Pressure Switch Solenoid 1 Circuit Fault</p>	<ol style="list-style-type: none"> 1. Let the vehicle idle with the parking brake applied, wheels chocked, and vehicle level. Check: <ol style="list-style-type: none"> a. Correct dipstick is installed. b. Fluid level is correct. 2. Check: <ol style="list-style-type: none"> a. Main transmission connector is tight, clean, and undamaged. b. TCM connector is tight, clean, and undamaged. c. PS1 diagnostic pressure switch has no opens, shorts-between-wires, or shorts-to-ground.

Code Listings And Procedures
(Allison 4th Generation Controls) (cont'd)

<p>P0880, P0881, P0882, P0883 TCM Power Input Signal Fault</p>	<ol style="list-style-type: none"> 1. Check: <ol style="list-style-type: none"> a. Battery direct ground and power connections are tight and clean. b. Vehicle batteries are charged. c. Vehicle charging system is not over- or under-charging. d. VIM fuse is good. e. VIM connections are tight, clean, and undamaged. f. Vehicle manufacturer supplied wiring is correct. g. TCM connection is tight, clean, and undamaged.
<p>P0894 Transmission Component Slipping</p>	<ol style="list-style-type: none"> 1. Let the vehicle idle with the parking brake applied, wheels chocked, and vehicle level. Check: <ol style="list-style-type: none"> a. Correct dipstick is installed. b. Fluid level is correct.
<p>P0960, P0964, P0968, P2727, P2736, P2761 Pressure Control Solenoid Circuit Open</p>	<ol style="list-style-type: none"> 1. Check: <ol style="list-style-type: none"> a. Main transmission connector is tight, clean, and undamaged. b. TCM connector is tight, clean, and undamaged. c. Wiring harness has no opens.
<p>P0962, P0965, P0970, P2720, P2729, P2738, P2764 Pressure Control Solenoid Circuit Low</p>	<ol style="list-style-type: none"> 1. Check: <ol style="list-style-type: none"> a. Main transmission connector is tight, clean, and undamaged. b. TCM connector is tight, clean, and undamaged. c. Wiring harness has no shorts-between-wires or shorts-to-ground.
<p>P0963, P0966, P0971, P2721, P2730, P2739, P2763 Pressure Control Solenoid Circuit High</p>	<ol style="list-style-type: none"> 1. Check: <ol style="list-style-type: none"> a. Main transmission connector is tight, clean, and undamaged. b. TCM connector is tight, clean, and undamaged. c. Wiring harness has no shorts-between-wires.

Code Listings And Procedures
(Allison 4th Generation Controls) (cont'd)

<p>P0973, P0976 Shift Solenoid Circuit Low</p>	<p>1. Check:</p> <ul style="list-style-type: none"> a. Main transmission connector is tight, clean, and undamaged. b. TCM connector is tight, clean, and undamaged. c. Wiring harness has no opens, shorts-between-wires, or shorts-to-ground.
<p>P0974, P0977 Shift Solenoid Circuit High</p>	<p>1. Check:</p> <ul style="list-style-type: none"> a. Main transmission connector is tight, clean, and undamaged. b. TCM connector is tight, clean, and undamaged. c. Wiring harness has no shorts-between-wires.
<p>P0975 Shift Solenoid Circuit Open</p>	<p>1. Check:</p> <ul style="list-style-type: none"> a. Main transmission connector is tight, clean, and undamaged. b. TCM connector is tight, clean, and undamaged. c. Wiring harness has no opens.
<p>P0989, P0990 Retarder Pressure Sensor Circuit Fault</p>	<p>1. Check:</p> <ul style="list-style-type: none"> a. Retarder pressure sensor connector is tight, clean, and undamaged. b. TCM connector is tight, clean, and undamaged. c. Retarder pressure circuit has no opens, shorts-between-wires, or shorts-to-ground.
<p>P1891, P1892 Throttle Position PWM Signal Circuit Fault</p>	<p>1. Check:</p> <ul style="list-style-type: none"> a. PWM throttle position sensor connector is tight, clean, and undamaged. b. TCM connector is tight, clean, and undamaged. c. PWM throttle position sensor circuit has no opens, shorts-between-wires, or shorts-to-ground.
<p>P2184, P2185 Engine Coolant Temp Sensor Circuit Fault</p>	<p>1. Check:</p> <ul style="list-style-type: none"> a. Engine coolant temperature sensor connector is tight, clean, and undamaged. b. TCM connector is tight, clean, and undamaged. c. Engine coolant temperature sensor circuit has no opens, shorts-between-wires, or shorts-to-ground.

Code Listings And Procedures
(Allison 4th Generation Controls) (cont'd)

<p>P2637, P2641 Torque Management Feedback Signal Fault</p>	<ol style="list-style-type: none"> 1. Check that no unauthorized engine power upgrades were made. 2. Check that engine software is compatible with transmission torque requirements, otherwise: <ol style="list-style-type: none"> a. Recalibrate engine controller with compatible software, or b. Reduce engine power and torque ratings.
<p>P2740 Retarder Oil Temperature Hot</p>	<ol style="list-style-type: none"> 1. Check: <ol style="list-style-type: none"> a. Transmission fluid level is correct. b. Retarder apply system is not allowing retarder and throttle to be applied at the same time. c. Vehicle manufacturer's transmission oil cooler is adequately sized for heat load.
<p>P2742, P2743 Retarder Oil Temperature Sensor Circuit Fault</p>	<ol style="list-style-type: none"> 1. Check: <ol style="list-style-type: none"> a. Retarder temperature measured with Allison DOC™ diagnostic tool is consistent with code, or determine if code is active using the shift selector. b. Retarder temperature sensor connector is tight, clean, and undamaged. c. TCM connector is tight, clean, and undamaged. d. Temperature sensor circuit has no opens, shorts-between-wires, or shorts-to-ground.
<p>P278A Kickdown Switch Circuit</p>	<ol style="list-style-type: none"> 1. Check input wiring, switches, and connectors to determine why kickdown input is not being sent to the TCM.
<p>P2793 Gear Shift Direction Circuit</p>	<ol style="list-style-type: none"> 1. Check: <ol style="list-style-type: none"> a. Shift selector connector is tight, clean, and undamaged. b. TCM connector is tight, clean, and undamaged. c. Gear shift direction circuit has no opens, shorts-between-wires, or shorts-to-ground.

Code Listings And Procedures
(Allison 4th Generation Controls) (cont'd)

<p>U0001 High Speed CAN Bus Reset Counter Overrun</p>	<p>1. Check:</p> <ul style="list-style-type: none"> a. High speed CAN connectors at engine and transmission controllers are tight, clean, and undamaged. b. High speed CAN wiring harness has no opens, shorts-between-wires, or shorts-to-ground. <ul style="list-style-type: none"> — The resistance between the CAN high and CAN low wires should be 60 Ohms.
<p>U0010 CAN Bus Reset Counter Overrun</p>	<p>1. Check:</p> <ul style="list-style-type: none"> a. J1939 CAN connectors at engine and transmission controllers are tight, clean, and undamaged. b. J1939 CAN wiring harness has no opens, shorts-between-wires, or shorts-to-ground. <ul style="list-style-type: none"> — The resistance between the CAN high and CAN low wires should be 60 Ohms.
<p>U0100 Lost Communica- tions with ECM/PCM (J1587)</p>	<p>1. Check:</p> <ul style="list-style-type: none"> a. Serial communications interface connections at engine are tight, clean, and undamaged. b. TCM connector is tight, clean, and undamaged. c. Serial communication interface wiring harness has no opens, shorts-between-wires, or shorts-to-ground.
<p>U0103, U0291 Lost Communica- tions with Gear Shift Module (Shift Selector)</p>	<p>1. Check:</p> <ul style="list-style-type: none"> a. Shift selector connector is tight, clean, and undamaged. b. TCM connector is tight, clean, and undamaged. c. Shift selector wiring harness has no opens, shorts-between-wires, or shorts-to-ground.
<p>U0115 Lost Communica- tions with ECM/PCM (J1939)</p>	<p>1. Check:</p> <ul style="list-style-type: none"> a. J1939 CAN connectors at engine and transmission controllers are tight, clean, and undamaged. b. J1939 CAN wiring harness has no opens, shorts-between-wires, or shorts-to-ground. <ul style="list-style-type: none"> — The resistance between the CAN high and CAN low wires should be 60 Ohms.

Code Listings And Procedures
(Allison 4th Generation Controls) (cont'd)

U0304, U0313 Incompatible Gear Shift Module	1. Check that the shift selector is an Allison supplied shift selector.
U0404, U0592 Invalid Data Received from Gear Shift Module	1. Check: <ul style="list-style-type: none">a. Shift selector connector is tight, clean, and undamaged.b. TCM connector is tight, clean, and undamaged.c. Shift selector wiring harness has no opens, shorts-between-wires, or shorts-to-ground.

MOTORHOME SERIES

ABBREVIATIONS AND DEFINITIONS

ABBREVIATIONS AND DEFINITIONS

ABS	A nti- l ock B rake S ystem—OEM-provided means to detect and prevent wheel stoppage to enhance vehicle handling. Retarder and engine brakes will not apply when ABS is active.
CT	C losed T hrottle
DOC	D iagnostic O ptimized C onnection
DTC	D iagnostic T rouble C ode
ECM	E lectronic C ontrol M odule—provides data to TCM/ECU.
ECU	E lectronic C ontrol U nit (also commonly referred to as the “computer” for WTEC III Controls)
EMI	E lectromagnetic I nterference
FCC	F ederal C ommunications C ommission
J1587	Engine/transmission serial data communications link.
J1939	High-speed vehicle serial data communications link.
LED	L ight- E mitting D iode—Electronic device used for illumination.
MH	M otor h ome S eries.
OEM	O riginal E quipment M anufacturer—Maker of vehicle or equipment.
OLS	O il L evel S ensor—Electronic device (optional) on control module for indicating transmission fluid level.

PC	Personal Computer —Needed to run a version of Allison DOC™ diagnostic tool.
PD	Powered Downshift —A downshift forced by applying brakes with the throttle applied. Allison Transmission does not recommend this procedure.
PDA	Personal Digital Assistant —Used to run a version of Allison DOC™ diagnostic tool.
PT	Part Throttle
PTO	Power Takeoff
RFI	Radio Frequency Interference
ST	Step Thru —A downshift forced by applying WOT, just prior to a CT downshift.
TCM	Transmission Control Module —(also commonly referred to as the “computer” for Allison 4 th Generation Controls)
TPS	Throttle Position Sensor —Potentiometer for signaling the position of the engine fuel control lever.
WOT	Wide Open Throttle
WTEC III	World Transmission Electronic Controls, Third Generation

MOTORHOME SERIES

CUSTOMER SERVICE

OWNER ASSISTANCE

The satisfaction and goodwill of the owners of Allison transmissions are of primary concern to Allison Transmission, its distributors, and their dealers.

As an owner of an Allison transmission, you have service locations throughout the world that are eager to meet your parts and service needs with:

- Expert service by trained personnel.
- Emergency service 24 hours a day in many areas.
- Complete parts support.
- Sales teams to help determine your transmission requirements.
- Product information and literature.

Normally, any situation that arises in connection with the sale, operation, or service of your transmission will be handled by the distributor or dealer in your area. Check the telephone directory for the Allison Transmission service outlet nearest you or utilize Allison Transmission's Sales and Service Locator tool on the Allison Transmission web site at www.allisontransmission.com. You may also refer to Allison Transmission's Worldwide Sales and Service Directory (SA2229EN).

We recognize, however, that despite the best intentions of everyone concerned, misunderstandings may occur. To further assure your complete satisfaction, we have developed the following three-step procedure to be followed in the event a problem has not been handled satisfactorily.

Step One—Discuss your problem with a member of management from the distributorship or dealership. Frequently, complaints are the result of a breakdown in communication and can quickly be resolved by a member of management. If you have already discussed the problem with the Sales or Service Manager, contact the General Manager. All Allison Transmission dealers are associated with an Allison Transmission distributor. If the problem originates with a dealer, explain the matter to a management member of the distributorship with

whom the dealer has his service agreement. The dealer will provide his Allison Transmission distributor's name, address, and telephone number on request.

Step Two—When it appears the problem cannot be readily resolved at the distributor level without additional assistance, **contact the Allison Technical Assistance Center at 800-252-5283**. They will place you in contact with the Regional Customer Support Manager for your area.

For prompt assistance, please have the following information available:

- Name and location of authorized distributor or dealer.
- Type and make of vehicle/equipment.
- Transmission model number, serial number, and assembly number (if equipped with electronic controls, also provide the TCM assembly number).
- Transmission delivery date and accumulated miles and/or hours of operation.
- Nature of problem.
- Chronological summary of your transmission's history.

Step Three—If you are still not satisfied after contacting the Regional Customer Support Manager, **present the entire matter to the Home Office by writing to the following address:**

Allison Transmission
Manager, Warranty Administration
PO Box 894, Mail Code 462-470-PF9
Indianapolis, IN 46206-0894

The inclusion of all pertinent information will assist the Home Office in expediting the matter.

When contacting the Home Office, please keep in mind that ultimately the problem will likely be resolved at the distributorship or dealership using their facilities, equipment, and personnel. Therefore, it is suggested that **Step One** be followed when experiencing a problem.

Your purchase of an Allison Transmission product is greatly appreciated, and it is our sincere desire to assure complete satisfaction.

SERVICE LITERATURE

Additional service literature is available as shown in the service literature table. This service literature provides fully illustrated instructions for the operation, maintenance, service, overhaul, and parts support of your transmission. To be sure that you get maximum performance and service life from your unit, you may order publications from:

SGI, Inc.

Attn: Allison Literature Fulfillment Desk

8350 Allison Avenue

Indianapolis, IN 46268

TOLL FREE: 888-666-5799

INTERNATIONAL: 317-471-4995

Available Service Literature (WTEC III Controls)

Transmission Model	3000 MH	4000 MH
Allison DOC™ For PC User Guide	GN3433EN	GN3433EN
Automatic Transmission Fluid Technician's Guide	GN2055EN	GN2055EN
Mechanic's Tips*	MT3004EN	MT3004EN
Operator's Manual (Motorhome Series) *	OM3349EN	OM3349EN
Parts Catalog*	PC2150EN	PC2456EN
Parts Catalog CD-ROM	CD2150EN	CD2456EN
Principles of Operation	PO2454EN	PO2454EN
Service Manual	SM2148EN	SM2457EN
Troubleshooting Manual	TS2973EN	TS2973EN
Worldwide Sales and Service Directory	SA2229EN	SA2229EN
* Also available on the Allison Transmission web site at www.allisontransmission.com		

Available Service Literature (Allison 4th Generation Controls)

Transmission Model	3000 MH	4000 MH
Allison DOC™ For PC User Guide	GN3433EN	GN3433EN
Mechanic's Tips (except 3700 7-speed)*	MT4015EN	MT4015EN
Operators Manual (Motorhome Series)*	OM3349EN	OM3349EN
Parts Catalog*	PC2150EN	PC2456EN
Parts Catalog on CD	CD2150EN	CD2456EN
Principles of Operation	PO4016EN	PO4016EN
Service Manual	SM4013EN	SM4014EN
Troubleshooting Manual	TS3989EN	TS3989EN
Worldwide Sales and Service Directory	SA2229EN	SA2229EN
* Also available on the Allison Transmission web site at www.allisontransmission.com		



ALLISON TRANSMISSION DISTRIBUTORS

EASTERN REGION

Atlantic Detroit Diesel-Allison, LLC 180 Route 17 South Lodi, NJ 07644 201-489-5800	Penn Detroit Diesel-Allison, Inc. 8330 State Road Philadelphia, PA 19136-2986 215-335-0500
Covington Detroit Diesel-Allison 8015 Piedmont Triad Parkway Greensboro, NC 27409 336-292-9240	Western Branch Diesel, Inc. 3504 Shipwright Street Portsmouth, VA 23703 757-673-7000
Johnson & Towers, Inc. 2021 Briggs Road Mount Laurel, NJ 08054 856-234-6990	W.W. Williams S.E., Inc. 2849 Moreland Avenue, S.E Atlanta, GA 30315-0037 404-366-1070
New England Detroit Diesel-Allison, Inc. 90 Bay State Road Wakefield, MA 01880-1095 781-246-1810	

CENTRAL REGION

Central Detroit Diesel-Allison, Inc. 9200 Liberty Drive Liberty, MO 64068 816-781-8070	Inland Detroit Diesel-Allison, Inc. 210 Alexandra Way Carol Stream, IL 60188 630-871-1111
Clarke Power Services, Inc. 3133 East Kemper Road Cincinnati, OH 45241 513-771-2200	Inland Diesel, Inc. 13015 West Custer Avenue Butler, WI 53007-0916 262-781-7100
Detroit Diesel-Allison Canada East Div. of Integrated Power Systems Corp. 2997 Rue Watt Ste. Foy, Quebec G1X 3W1 418-651-5371	Interstate PowerSystems, Inc. 2501 American Boulevard, East Minneapolis, MN 55425 952-854-5511
Harper Detroit Diesel Ltd. 10 Diesel Drive Toronto, Ontario M8W 2T8 416-259-3281	W.W. Williams M.W., Inc. 1176 Industrial Parkway North Brunswick, OH 44212-2342 330-225-7751

SOUTHERN REGION

Caribe Detroit Diesel-Allison Division of GT Corporation Ceramic Ind. Park Campo Rico Ave., Block C Carolina, Puerto Rico 00982 787-750-5000	Stewart & Stevenson Power, Inc. 5840 Dahlia Street Commerce City, CO 80022 303-287-7441
Detroit Diesel-Allison de Mexico S.A. de C.V. Av. Santa Rosa No. 58 Col. Ampliacion Norte Tlalnepantla C.P. 54160, Estado de Mexico 525-5-5333-1800	Stewart & Stevenson Services, Inc. 2707 North Loop West Houston, TX 77008 713-868-7700
Florida Detroit Diesel-Allison, Inc. 2277 N.W. 14th Street Miami, FL 33125-0068 904-737-7330	United Engines, LLC 5555 West Reno Street Oklahoma City, OK 73127 405-947-3321

WESTERN REGION

Detroit Diesel-Allison British Columbia Ltd. 9300 - 192nd Street Surrey, British Columbia V4N 3R8 604-888-1211	Stewart & Stevenson 1755 Adams Avenue San Leandro, CA 94577-1001 510-635-8991
Midwest Detroit Diesel-Allison Ltd. 1460 Waverly Street Winnipeg, Manitoba R3T OP6 204-452-8244	Valley Power Systems, Inc. 425 South Hacienda Boulevard City of Industry, CA 91745-1123 626-333-1243
Pacific Detroit Diesel-Allison Company 7215 South 228th Street Kent, WA 98032 253-854-0505	Waterous Power Systems 10025 - 51 Avenue Edmonton, Alberta T6E OA8 780-437-3550
Smith Detroit Diesel-Allison, Inc. 3065 West California Avenue Salt Lake City, UT 84104 801-415-5000	W.W. Williams S.W., Inc. 2602 S. 19th Avenue Phoenix, AZ 85009 602-257-0561

ALLISON TRANSMISSION REGIONAL OFFICES

EASTERN REGION

19 Oaklynn Drive
PO Box 400
Columbus, NJ 08022-0400
609-298-2541

CENTRAL REGION

PO Box 894, Mail Code 462-470-PF06
Indianapolis, IN 46206-0894
317-242-2327

SOUTHERN REGION

Av. Ejercito Nacional No. 843
Colonia Granada
Mexico, D.F. C.P. 11520
936-321-4248

WESTERN REGION

Suite 3510
39465 Paseo Padre Parkway
Fremont, CA 94538
510-226-8037

MOTORHOME SERIES